



CATALOGO RICAMBI
SPARE PARTS CATALOG
CATALOGUE PIECES DE RECHANGE
ERZATZ TEILKATALOG
CATALOGO PIEZAS DE REPUESTOS



CH 507 JUNIOR - CH 516 PRO JUNIOR

ED. 05/2003 REV.00

INFORMAZIONI GENERALI

Nelle ordinazioni indicare:

- 1) Il modello e il numero di matricola del motociclo, stampigliato sul canotto di sterzo.
- 2) Il numero di codice dei particolari seguito dalla descrizione.

GENERAL INFORMATION

When ordering specify:

- 1) The motorcycle's model and serial number, see label on the steering head.;
- 2) The part's code number followed by its description;

INFORMATIONS GENERALES

Les commandes doivent être passées en indiquant:

- 1) Le modèle et le numéro matricule de la moto, voir sur la tige du guidon.
- 2) Le numéro de code des pièces détachées suivi de leur description;

ALLGEMEINE HINWEISE

Bei Ersatzbestellung ist folgendes anzugeben:

- 1) Der Modell und die Seriennummer des Motorrads, die am Lenkrohr eingepägt ist.
- 2) Die Bestellnummer der Ersatzteile mit der entsprechenden Beschreibung.

INFORMACIONES GENERALES

En los pedidos se debe indicar:

- 1) El modelo y el número de serie de la motocicleta, grabados en el tubo de dirección.
- 2) El número de código de la parte y a continuación la descripción;

Modello

Model
Medele
Model
Modelo

N° di serie Telaio

Chassis serial number
N° de série du châssis
Serien-Nummer des Rahmen
Numero chasis



Pos.

No
N.
Index
Pos.

N codice.

Code No.
Nr. code
Code Nr
N. cod.

Denominazione

Description
Designation
Bezeichnung
Denominación

CH 507 - CH 516

Ed. 05/02

TAVOLA - DRAWING
TABLE - BILD - TABLA

1

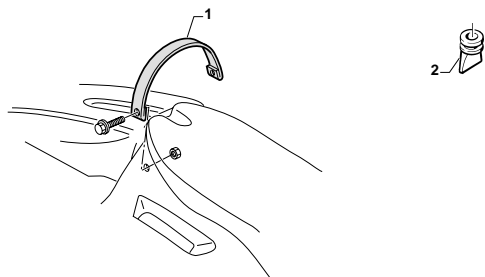

ACCESSORI OPZIONALI - OPTIONAL ACCESSORIES - ACCESSOIRES EN OPTION
OPTIONALE ZUBEHÖRE - ACCESORIOS EN OPCION

CH 507 - CH 516

Ed. 05/02

TAVOLA - DRAWING
TABLE - BILD - TABLA

1

Pos. No. N. Index. Pos.	N.codice Code No. Nr. code Code Nr. N. cod.	Denominazione	Description	Désignation	Beschreibung	Descripción	Note Notes Notes Marke Notes	Q.tà Q.ty Q.te M.ge C.ad
1	XH248100	Maniglia	Handle	Poignée	Handgriff	Manilla		1
2	XH248000	Valvola	Valve	Soupape	Ventil	Válvula		1

INDICE – INDEX – INDEX – INHALTSVERZEICHNIS - INDICE

Tavola
Drawing
Table
Bild
Tabla

	Denominazione	Description	Designation	Bezeichnung	Denominacion	Pag
1	ACCESSORI OPZIONALI	OPTIONAL ACCESSORIES	ACCESSOIRES EN OPTION	OPTIONALE ZUBEHÖRE	ACCESORIOS EN OPCIÓN	5
2	MOTORE	ENGINE	MOTEUR	MOTORS	MOTOR	7
3	MOTORE	ENGINE	MOTEUR	MOTORS	MOTOR	9
4	MOTORE	ENGINE	MOTEUR	MOTORS	MOTOR	11
5	MOTORE	ENGINE	MOTEUR	MOTORS	MOTOR	13
6	MOTORE	ENGINE	MOTEUR	MOTORS	MOTOR	15
7	MOTORE	ENGINE	MOTEUR	MOTORS	MOTOR	17
8	MOTORE	ENGINE	MOTEUR	MOTORS	MOTOR	19
8A	MOTORE	ENGINE	MOTEUR	MOTORS	MOTOR	21
9	CARBURATORE	CARBURETOR	CARBURATEUR	VERGASER	CARBURADOR	23
10	FILTRO ARIA	AIR FILTER	FILTRE AIRE	AIRFILTER	FILTRO DE AIRE	25
11	TELAIO, PEDANE	FRAME, FOOT RESTS	CADRE, REPOSE PIEDS	RAHMEN - FUSSBRETT	BASTIDOR, REPOSAPIES	27
12	FORCELLONE E SOSP. POSTERIORE	SWING ARM AND REAR SUSPENSION	FOURCHE ET SUSPENSION ARRIÈRE	GABEL UND HINTERHAUFHÄNGUNG	HORQUILLA Y SUSPENSION TRASERA	29
13	SOSPENSIONE ANTERIORE	FRONT FORK ASSEMBLY	SUSPENSION AVANT	VORDERTELESKOPGABEL	SUSPENSION DELANTERA	31
14	SCARICO	EXHAUST SYSTEM	TUYAU D'ÉCHAPPEMENT	AUSPUFFROHR	TUBO DE ESCAPE	33
15	MANUBRIO E COMANDI	HANDLEBAR AND CONTROLS	GUIDON ET COMMANDES	LENKER UND STEUERORGANE	MANILLAR Y MANDOS	35
16	CARENATURE E PARAFANGHI	FAIRING AND MUDGUARD	CARENATURE ET GARDE-BOUE	HINTERSCHALE UND KOTFLUEGEL	CARROCERIA Y GUARDA-BARROS	37
17	RUOTA ANTERIORE, RUOTA POSTERIORE	FRONT WHEEL, REAR WHEEL	ROUE AV., ROUE ARRIÈRE	VORTERRAD, RUEDA DELANTERA	HINTERRAD, RUEDA TRASERA	39
18	RAFFREDDAMENTO	WATER COOLING	REFROIDISSEMENT	WASSERKÜHLUNG	ENFRIAMIENTO	41

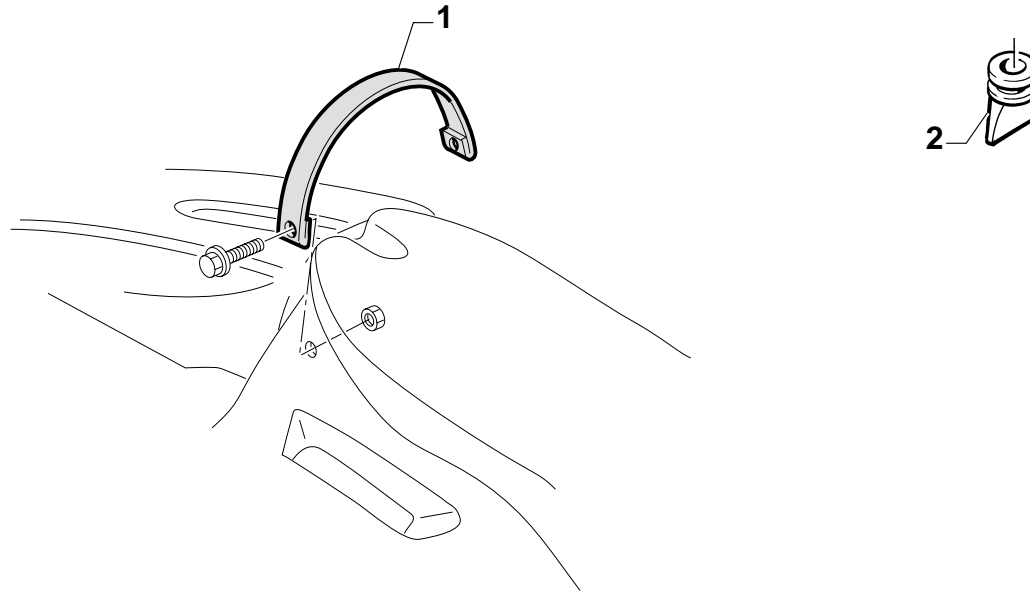

Pos. No. N. Index. Pos.	N.codice Code No. Nr. code Code Nr. N. cod.	Denominazione	Description	Désignation	Beschreibung	Descripción	Note Notes Notes Marke Notas	Q.tà Q.ty Q.te M.ge C.ad
1	XH248100	Maniglia	Handle	Poignée	Handgriff	Manilla		1
2	XH248000	Valvola	Valve	Soupape	Ventil	Válvula		1

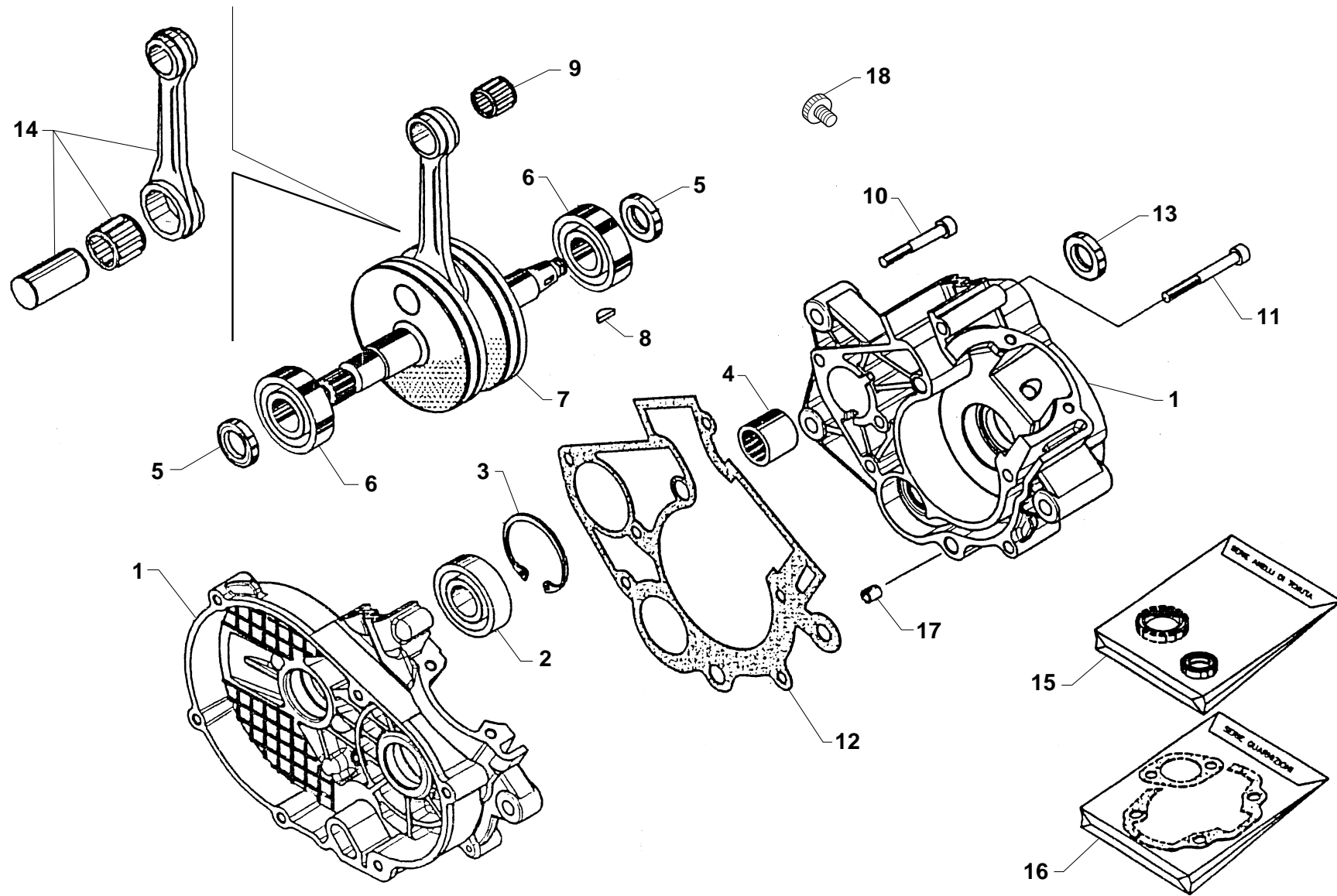

Pos. No. N. Index. Pos.	N.codice Code No. Nr. code Code Nr. N. cod.	Denominazione	Description	Désignation	Beschreibung	Descripción	Note Notes Notes Marke Notas	Q.tà Q.ty Q.te M.ge C.ad
1	EM1206.90	Carter	Complete carter	Carter	Gehaeuse	Càrter	507	1
1	EM1206.91	Carter	Complete carter	Carter	Gehaeuse	Càrter	516	1
2	EM1260.67	Cuscinetto	Bearing	Roulement	Lager	Cojinete		1
3	EM1050.70	Anello elastico	Ring	Bague	Ring	Aros de embolo		1
4	EM1085.12	Astuccio	Needle bearing	Etui	Buechse	Estuche		1
5	EM1060.33	Anello tenuta	Seal	Anneu	Dichtring	Junta		2
6	EM1260.21	Cuscinetto	Bearing	Roulement	Lager	Cojinete		2
7	EM1001.89	Albero motore	Shaft	Arbre	Welle	Ciguenal		1
8	EM1270.25	Chiavetta	Key	Clavette	Keil	Clave		1
9	EM1610.24	Gabbia	Cage	Cage	Lagerkcafig	Jaula		1
10	EM2919.93	Vite	Screw	Vis	Schraube	Tornillo		1
11	EM2919.91	Vite	Screw	Vis	Schraube	Tornillo		7
12	EM1642.97	Guarnizione	Gasket	Garnitue	Dichtung	Junta		1
13	EM1060.34	Anello	Ring	Bague	Ring	Anillo		1
14	EM1100.41	Biella completa	Con.rod	Bielle	Pleuel	Biela		1
15	EM2605.36	Serie anelli	Rings set	Serie bagues	Ringsatz	Serie de aros		1
16	EM2606.57	Serie guarniz.	Gasket set	Jeux de garnitu	Satz aus belag	Juego de forro		1
17	EM2681.27	Spina	Pin	Goupille	Stift	Clavija		2
18	EM2511.79	Raccordo	Union	Raccord	Anschluss	Empalme	516	1

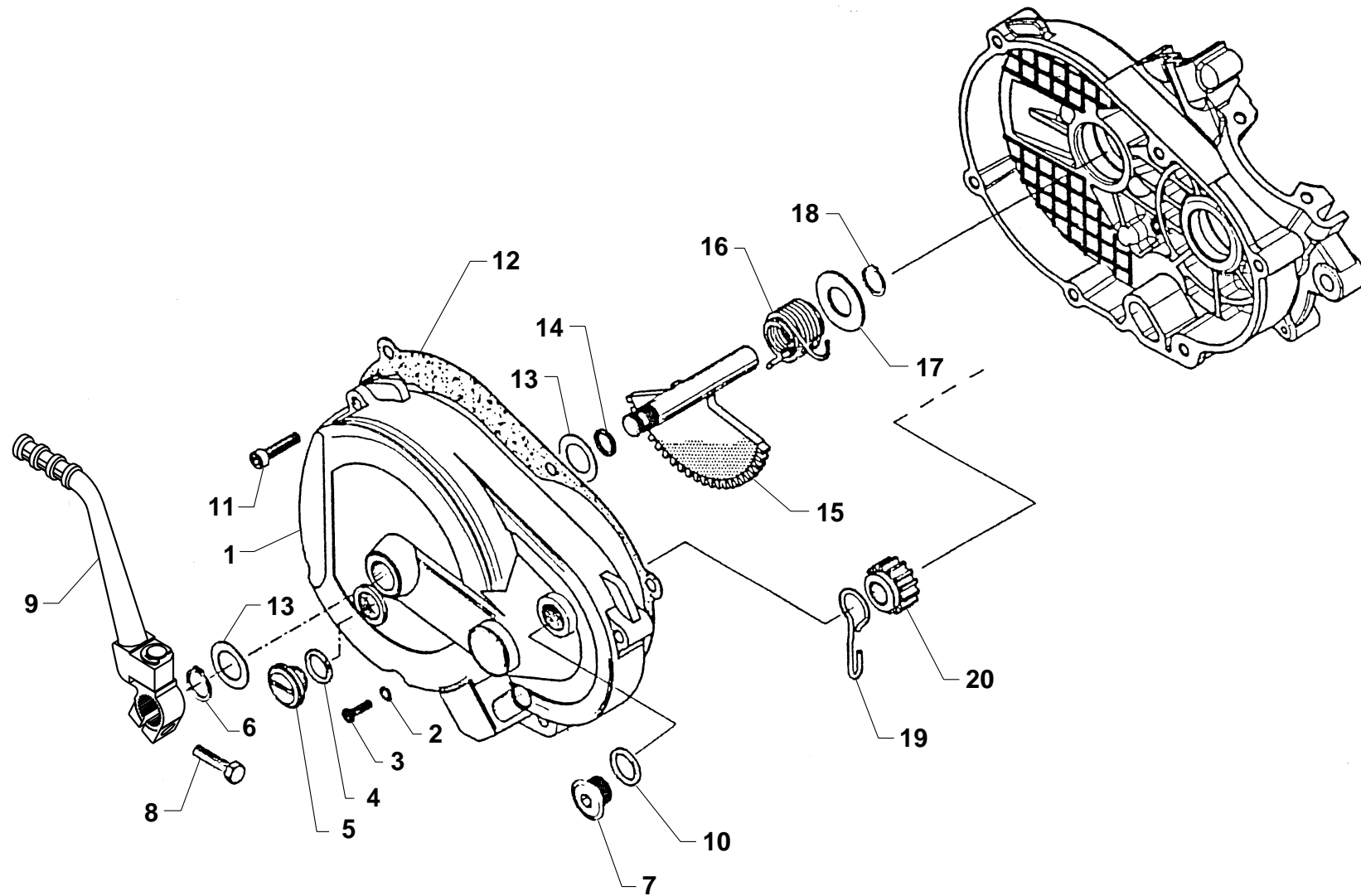

Pos. No. N. Index. Pos.	N.codice Code No. Nr. code Code Nr. N. cod.	Denominazione	Description	Désignation	Beschreibung	Descripción	Note Notes Notes Marke Notas	Q.tà Q.ty Q.te M.ge C.ad
1	EM1208.25	Coperchio	Cover	Couvercle	Deckel	Tapa	516	1
1	EM1242.76	Coperchio	Cover	Couvercle	Deckel	Tapa	507	1
2	EM1640.69	Guarnizione	Gasket	Garnitue	Dichtung	Junta		1
3	EM2961.44	Vite	Screw	Vis	Schraube	Tornillo		1
4	EM1640.26	Guarnizione	Gasket	Garnitue	Dichtung	Junta		1
5	EM2730.07	Tappo	Plug	Bouchon	Verschluss	Tapón		1
6	EM1050.53	Anello	Ring	Bague	Ring	Anillo		1
7	EM2730.46	Tappo	Plug	Bouchon	Verschluss	Tapón		1
8	EM2919.85	Vite	Screw	Vis	Schraube	Tornillo		1
9	EM1900.52	Leva	Lever	Levier	Hebel	Palanca		1
10	EM1640.09	Guarnizione	Gasket	Garnitue	Dichtung	Junta		1
11	EM2919.87	Vite	Screw	Vis	Schraube	Tornillo		6
12	EM1642.96	Guarnizione	Gasket	Garnitue	Dichtung	Junta		1
13	EM2540.0508	Rondella	Washer	Rondelle	Scheibe	Arandela		2
14	EM1070.24	Anello	Ring	Bague	Ring	Anillo		1
15	EM1001.88	Albero	Shaft	Arbre	Welle	Eje		1
16	EM2011.81	Molla	Spring	Ressort	Feder	Resorte		1
17	EM2540.10	Rondella	Washer	Rondelle	Scheibe	Arandela		1
18	EM1050.01	Anello	Ring	Bague	Ring	Anillo		1
19	EM2011.97	Molla	Spring	Ressort	Feder	Resorte		1
20	EM1813.00	Ingranaggio	Gear	Engrenage	Zahnrad	Engranaje		1

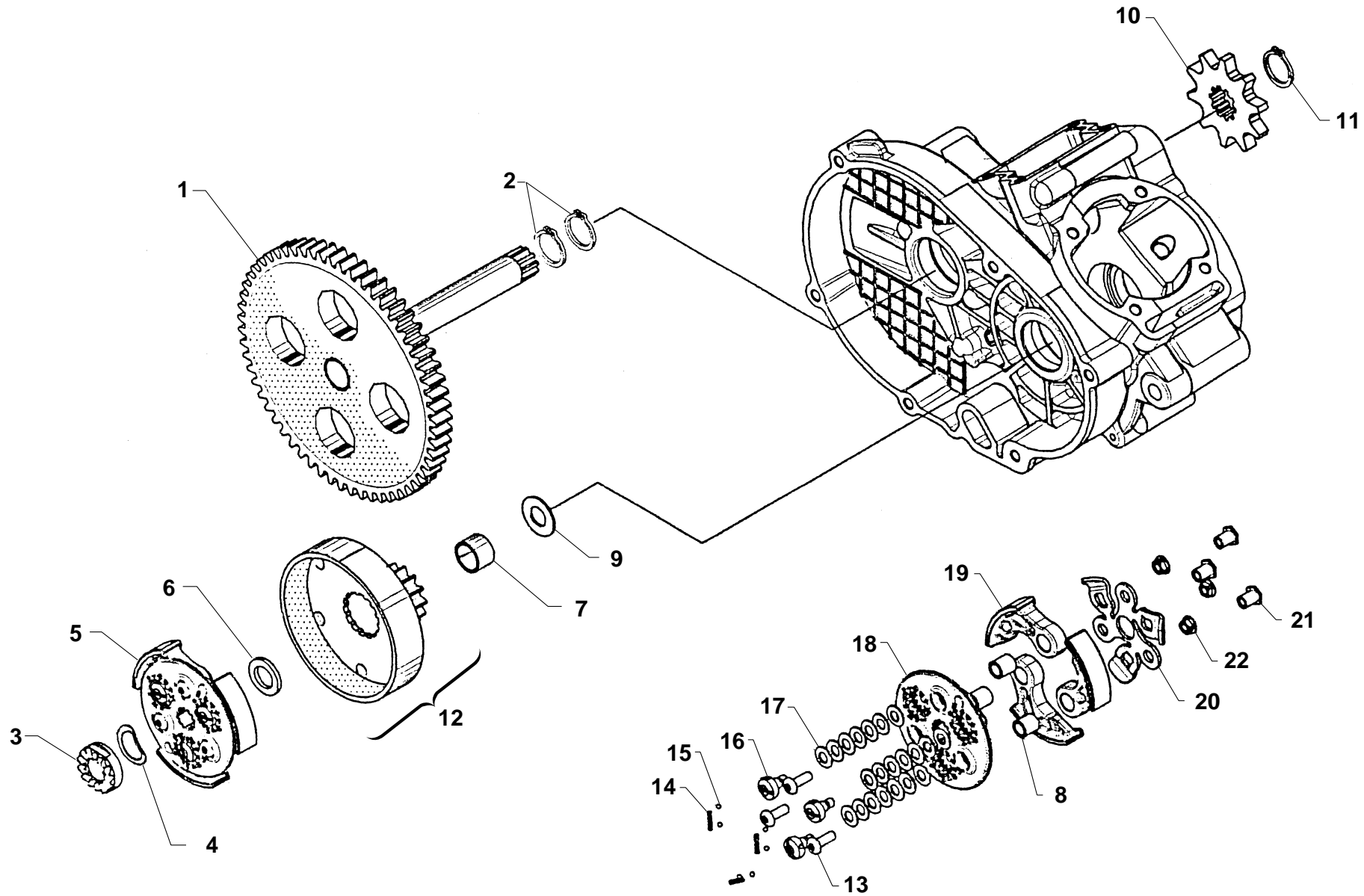

Pos. No. N. Index. Pos.	N.codice Code No. Nr. code Code Nr. N. cod.	Denominazione	Description	Désignation	Beschreibung	Descripción	Note Notes Notes Marke Notas	Q.tà Q.ty Q.te M.ge C.ad
1	EM1207.22	Corona	Ring gear	Couronne	Kranz	Corona		1
2	EM1050.35	Anello	Ring	Bague	Ring	Anillo		2
3	EM1310.35	Dado	Nut	Ecrou	Mutter	Tuerca		1
4	EM2011.95	Molla	Spring	Ressort	Feder	Resorte		1
5	EM1500.95	Frizione	Clutch	Embrayage	Kupplung	Embrague		1
6	EM1361.30	Distanziale	Spacer	Entretoise	Distanzstück	Separador		1
7	EM1150.97	Boccola	Bush	Douille	Buchse	Casquillo		1
8	EM1151.02	Boccola	Bush	Douille	Buchse	Casquillo		3
9	EM2540.0506	Rondella	Washer	Rondelle	Scheibe	Arandela		1
10	EM2326.08	Pignone	Pinion	Pignon	Ritzel	Piñón	507	1
11	EM1050.35	Anello	Ring	Bague	Ring	Anillo		1
12	EM1800.31	Ingranaggio	Gear	Engrenage	Zahnrad	Engranaje		1
13	EM2961.26	Vite	Screw	Vis	Schraube	Tornillo		3
14	EM2011.86	Molla	Spring	Ressort	Feder	Resorte		3
15	EM2682.41	Sfera	Ball	Bille	Kugel	Esfera		3
16	EM2961.27	Vite	Screw	Vis	Schraube	Tornillo		3
17	EM2011.96	Molla	Spring	Ressort	Feder	Resorte		21
18	EM2371.42	Piattello	Plate	Plateau	Teller	Placa		1
19	EM2000.92	Massa	Masselotte	Fliehwicht	Weight	Contrapeso		3
20	EM2011.84	Molla	Spring	Ressort	Feder	Resorte		1
21	EM2140.13	Nottolino	Pawl	Cliquet	Klinke	Pestillo		3
22	EM2771.58	Tenditore	Turnbuckle	Tendeur	Spanner	Tensor		3

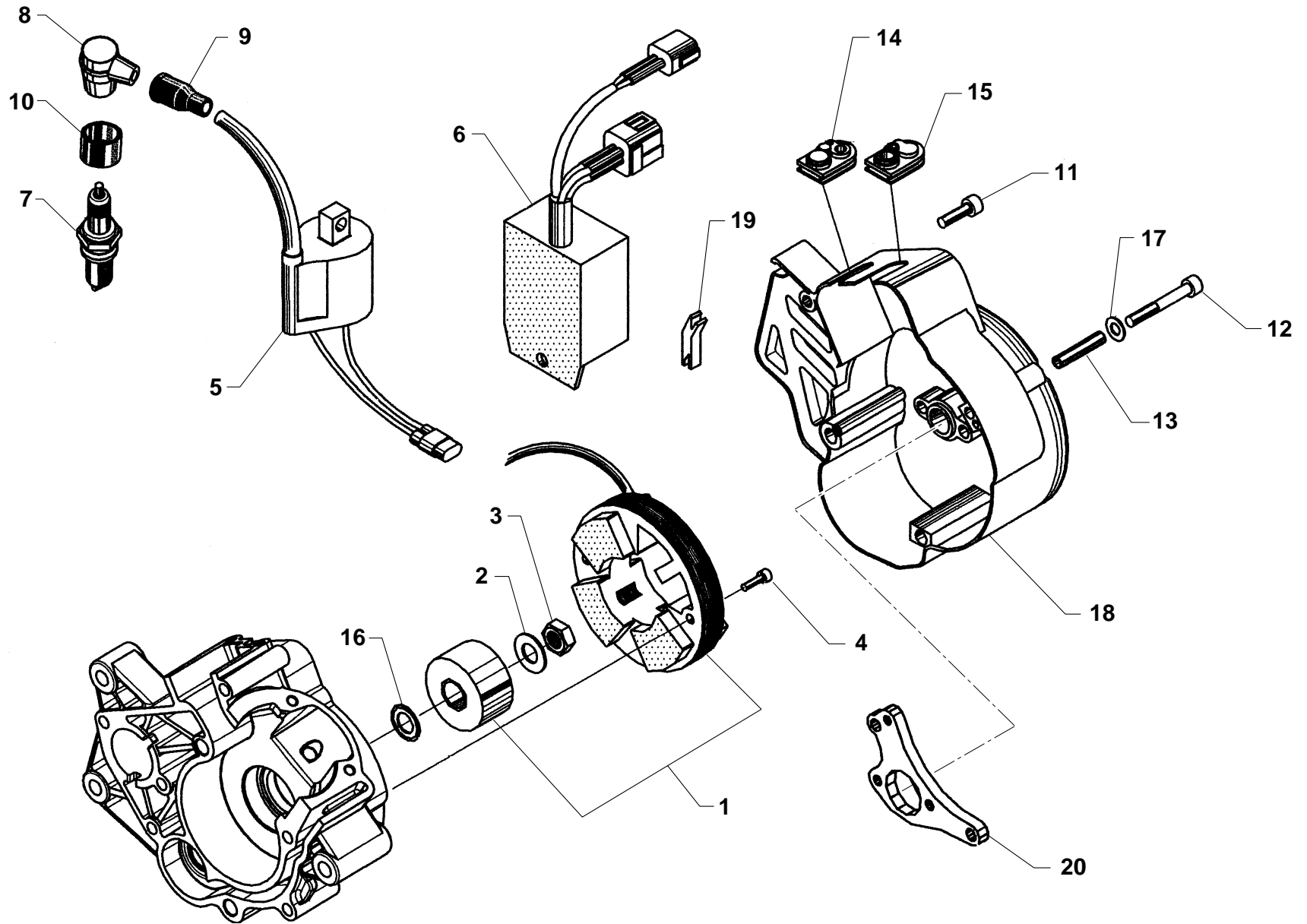

Pos. No. N. Index. Pos.	N.codice Code No. Nr. code Code Nr. N. cod.	Denominazione	Description	Désignation	Beschreibung	Descripción	Note Notes Notes Marke Notas	Q.tà Q.ty Q.te M.ge C.ad
1	EM2901.59	Volano	Flywheel	Volant	Schwungmasse	Volante		1
2	EM2540.23	Rondella	Washer	Rondelle	Scheibe	Arandela		1
3	EM1310.27	Dado	Nut	Ecrou	Mutter	Tuerca		1
4	EM2919.33	Vite	Screw	Vis	Schraube	Tornillo		2
5	EM140004	Bobina	Coil	Bobine	Zündspule	Bobina		1
6	EM1410.72	Centralina	Hydraul.attach.	Dispos.hydraul.	Hydr.einheit	Controller		1
7	EM1273.48	Candela	Spark plug	Bougie	Zündkerze	Bujía		1
8	EM2371.46	Pipetta	Pipette	Pipette	Pipette	Pipa		1
9	EM1630.51	Gommino	Rubber pad	Pièce caoutchouc	Gummistück	Junta de goma		1
10	EM1630.58	Rondella	Washer	Rondelle	Scheibe	Arandela		1
11	EM2919.59	Vite	Screw	Vis	Schraube	Tornillo		1
12	EM2919.66	Vite	Screw	Vis	Schraube	Tornillo		3
13	EM1670.56	Grano	Dowel	Goujon	Stift	Clavija		2
14	EM1630.75	Gommino	Rubber pad	Pièce caoutchouc	Gummistück	Junta de goma		1
15	EM1630.79	Gommino	Rubber pad	Pièce caoutchouc	Gummistück	Junta de goma		1
16	EM2542.30	Rondella	Washer	Rondelle	Scheibe	Arandela		1
17	EM2542.40	Rondella	Washer	Rondelle	Scheibe	Arandela		4
18	EM1242.60	Volano	Flywheel	Volant	Schwungmasse	Volante		1
19	EM1630.81	Gommino	Rubber pad	Pièce caoutchouc	Gummistück	Junta de goma	507	1
20	EM2682.57	Staffa	Bracket	Etrier	Buegel	Brida		1

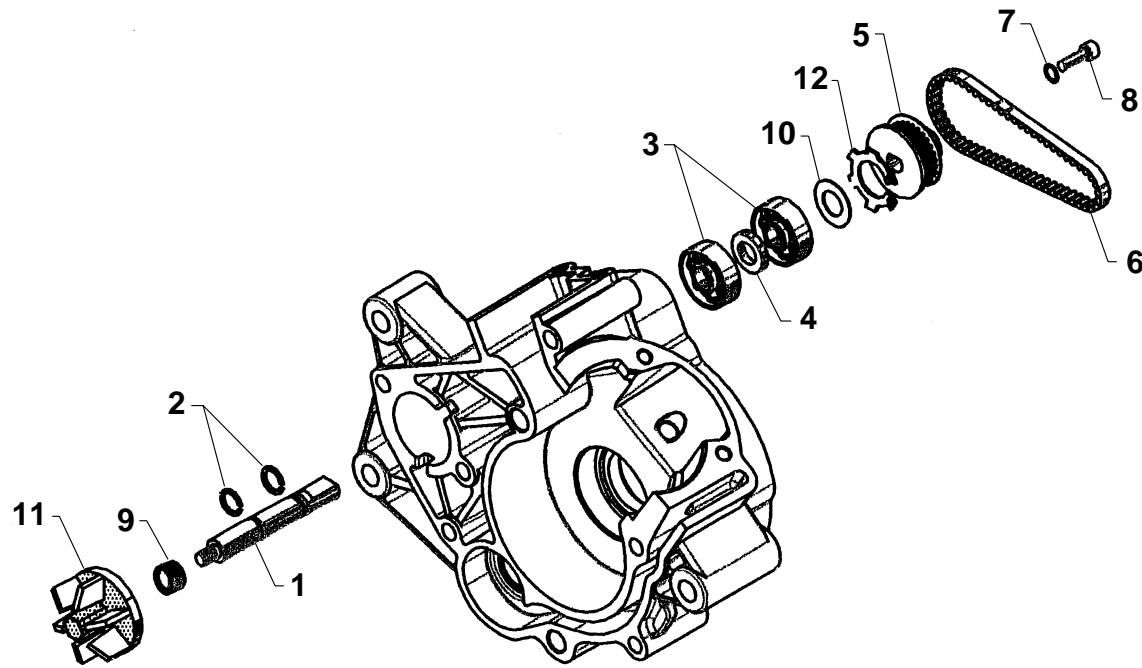

Pos. No. N. Index. Pos.	N.codice Code No. Nr. code Code Nr. N. cod.	Denominazione	Description	Désignation	Beschreibung	Descripción	Note Notes Notes Marke Notas	Q.tà Q.ty Q.te M.ge C.ad
1	EM1012.37	Albero	Shaft	Arbre	Welle	Eje		1
2	EM1050.61	Anello	Ring	Bague	Ring	Anillo		2
3	EM1260.38	Cuscinetto	Bearing	Roulement	Lager	Cojinete		2
4	EM1361.25	Distanziale	Spacer	Entretoise	Distanzstück	Separador		1
5	EM2300.91	Puleggia	Pulley	Poulie	Rolle	Polea		1
6	EM127335	Cinghia	Belt	Courroie	Riemen	Correa		1
7	EM2540.86	Rondella	Washer	Rondelle	Scheibe	Arandela		1
8	EM2919.31	Vite	Screw	Vis	Schraube	Tornillo		1
9	EM1060.79	Anello	Ring	Bague	Ring	Anillo		1
10	EM2542.27	Rondella	Washer	Rondelle	Scheibe	Arandela		1
11	EM167031	Girante	Rotor	Couronne	Lauftrad	Rotor		1
12	EM1370.06	Dischetto	Disk	Disque	Scheibe	Disco		1

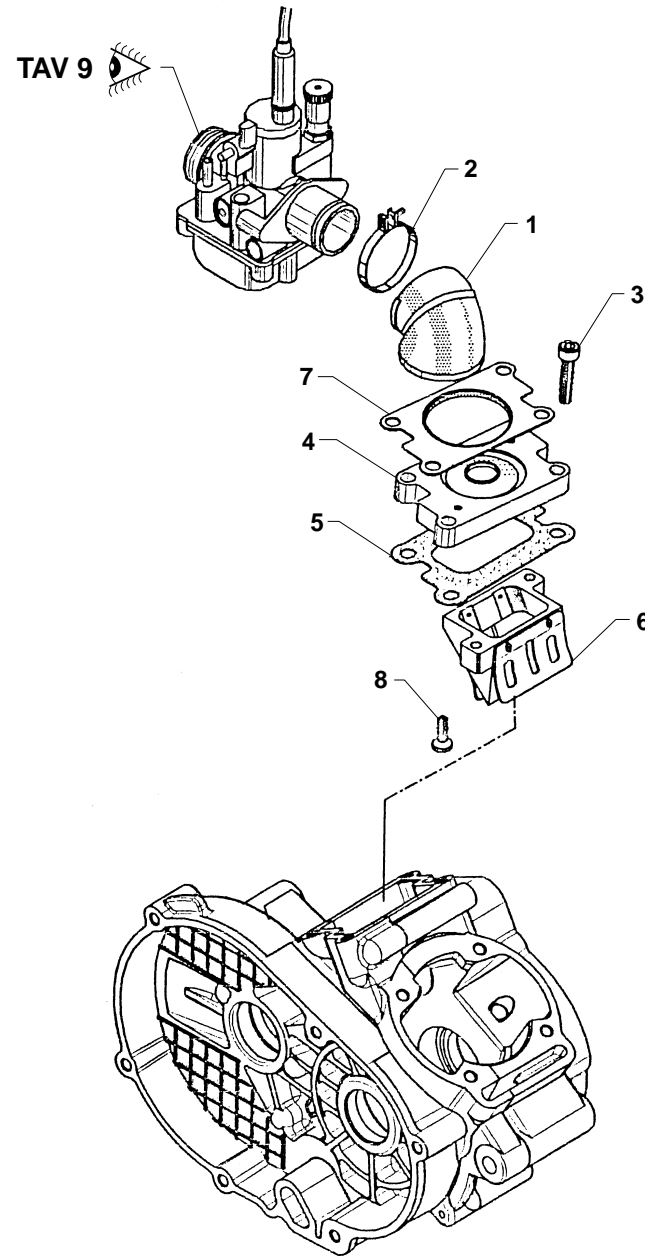

Pos. No. N. Index. Pos.	N.codice Code No. Nr. code Code Nr. N. cod.	Denominazione	Description	Désignation	Beschreibung	Descripción	Note Notes Notes Marke Notas	Q.tà Q.ty Q.te M.ge C.ad
1	EM2060.89	Manicotto	Sleeve	Manchon	Muffe	Manguito		1
2	EM1510.15	Fascetta	Clamp	Collier	Schelle	Banda		1
3	EM2919.86	Vite	Screw	Vis	Schraube	Tornillo		4
4	EM1180.27	Base raccordo carb.	Base	Socle	Lager	Base		1
5	EM1642.98	Guarnizione	Gasket	Garnitue	Dichtung	Junta		1
6	EM2905.41	Valvola	Valve	Soupape	Ventil	Válvula		1
7	EM2371.40	Piastrina ritegno	Plate	Plaquette	Plättchen	Placa		1
8	EM2960.51	Vite	Screw	Vis	Schraube	Tornillo		2

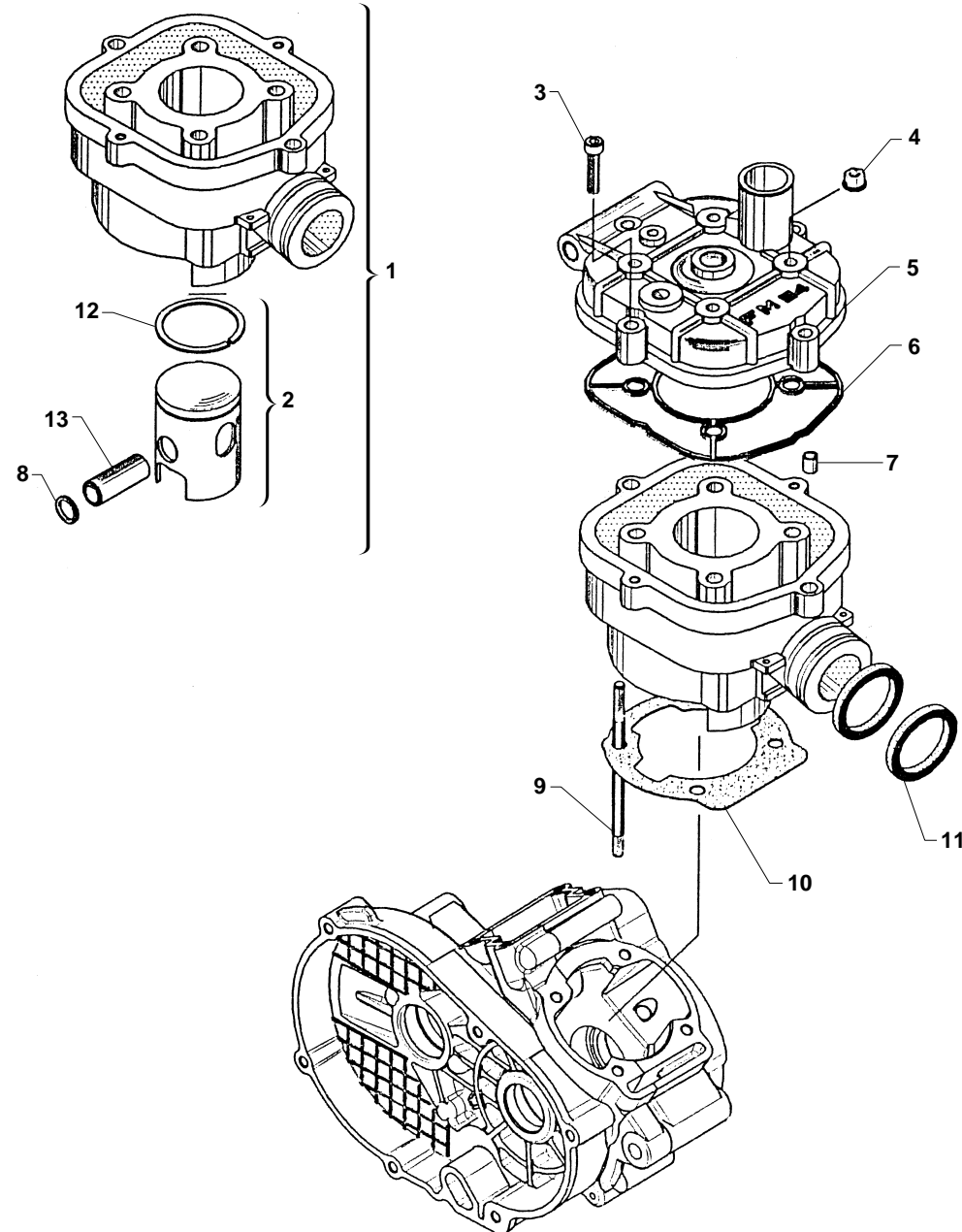

Pos. No. N. Index. Pos.	N.codice Code No. Nr. code Code Nr. N. cod.	Denominazione	Description	Désignation	Beschreibung	Descripción	Note Notes Notes Marke Notas	Q.tà Q.ty Q.te M.ge C.ad
1	EM7739.68	Cilindro + pistone	Cylinder + Piston	Cylindre + Piston	Zylinder + Kolben	Cilindro + Embolo		1
2	EM2301.83	Pistone	Piston	Piston	Kolbe	Pistón		1
3	EM2919.87	Vite	Screw	Vis	Schraube	Tornillo		4
4	EM1310.30	Dado	Nut	Ecrou	Mutter	Tuerca		4
5	EM2750.94	Testa	Cylinder head	Tetedu cylindre	Zylinderkopf	Cabeza		1
6	EM1070.18	Anello	Ring	Bague	Ring	Anillo		1
7	EM1670.08	Grano	Dowel	Goujon	Stift	Clavija		2
8	EM1040.01	Anello ferma spinotto	Ring	Bague	Ring	Anillo		2
9	EM2350.55	Prigioniero	Stud bolt	Prisonnier	Stiftschraube	Prisionero		4
10	EM1642.95	Guarnizione	Gasket	Garnitue	Dichtung	Junta		1
11	EM1070.65	Anello	Ring	Bague	Ring	Anillo		2
12	EM2610.56	Segmento	Circlip	Segment	Kolbenring	Segmento		1
13	EM2681.07	Spinotto	Gudgeon	Axe	Bolzen	Perno		1

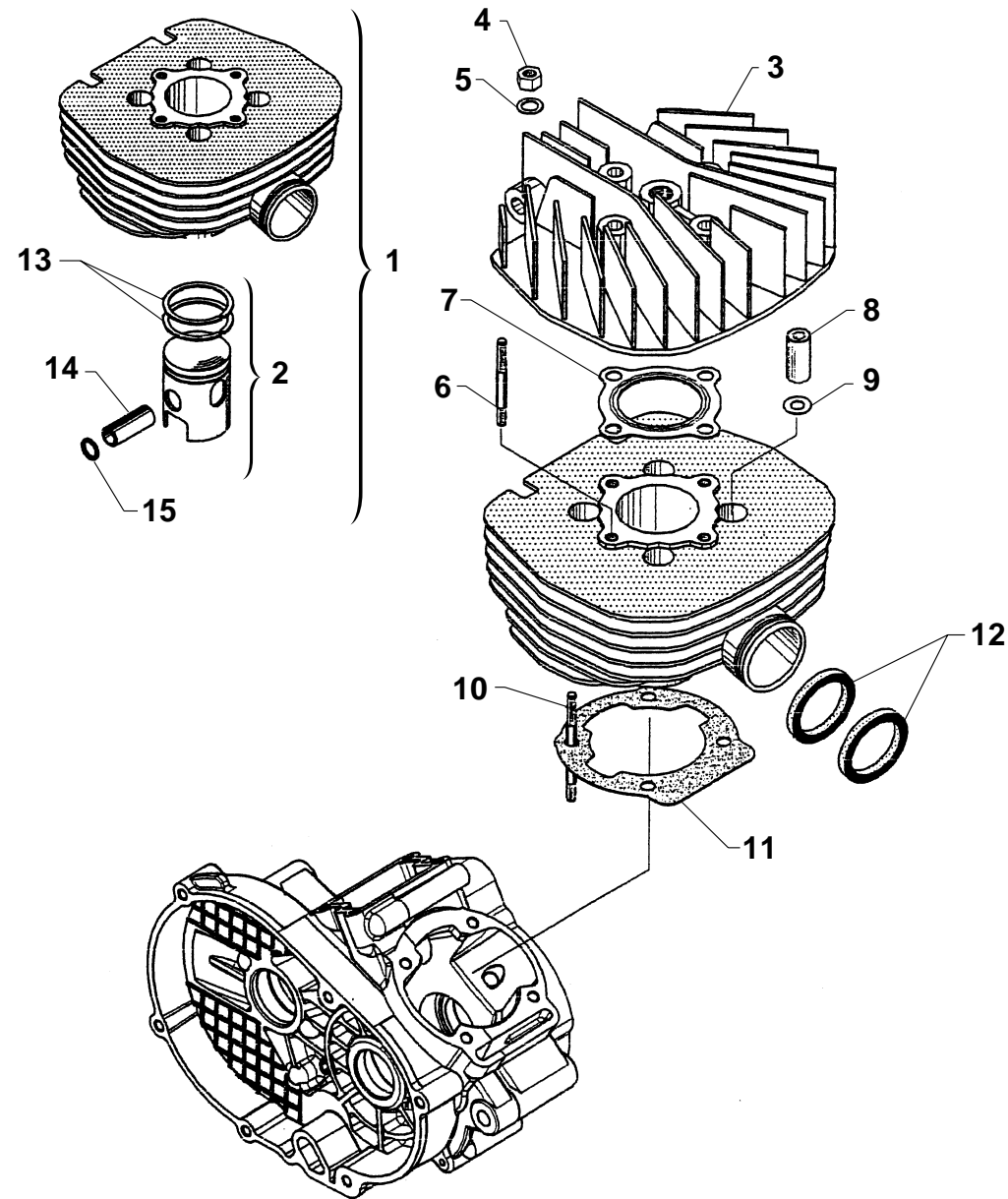

Pos. No. N. Index. Pos.	N.codice Code No. Nr. code Code Nr. N. cod.	Denominazione	Description	Désignation	Beschreibung	Descripción	Note Notes Notes Marke Notas	Q.tà Q.ty Q.te M.ge C.ad
1	EM7739.66	Cilindro	Cylinder	Cylindre	Zylinder	Cilindro		1
2	EM2301.82	Pistone	Piston	Piston	Kolbe	Pistón		1
3	EM2750.91	Testa	Cylinder head	Tetedu cylindre	Zylinderkopf	Cabeza		1
4	EM1310.05	Dado	Nut	Ecrou	Mutter	Tuerca		4
5	EM2540.81	Rondella	Washer	Rondelle	Scheibe	Arandela		4
6	EM2350.32	Prigioniero	Stud bolt	Prisonnier	Stiftschraube	Prisionero		4
7	EM1643.09	Guarnizione	Gasket	Garnitue	Dichtung	Junta		1
8	EM1273.36	Colonna	Stud bolt	Colonnette	Dorn	Esparrago		4
9	EM2540.01	Rondella	Washer	Rondelle	Scheibe	Arandela		8
10	EM2350.51	Prigioniero	Stud bolt	Prisonnier	Stiftschraube	Prisionero		4
11	EM1642.95	Guarnizione	Gasket	Garnitue	Dichtung	Junta		1
12	EM1070.65	Anello	Ring	Bague	Ring	Anillo		2
13	EM2610.56	Segmento	Circlip	Segment	Kolbenring	Segmento		2
14	EM2681.07	Spinotto	Gudgeon	Axe	Bolzen	Perno		1
15	EM1040.01	Anello	Ring	Bague	Ring	Anillo		2

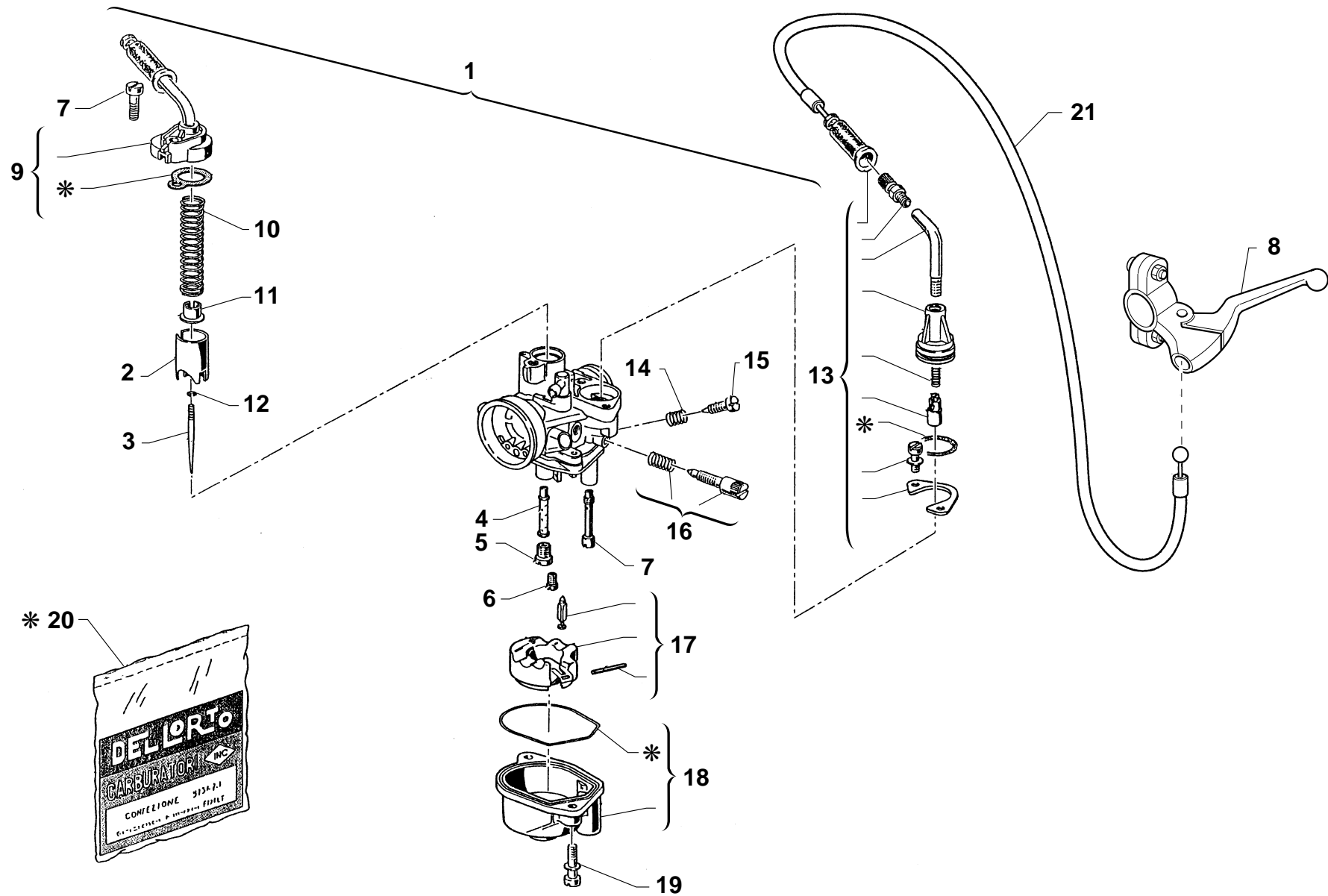

Pos. No. N. Index. Pos.	N.codice Code No. Nr. code Code Nr. N. cod.	Denominazione	Description	Désignation	Beschreibung	Descripción	Note Notes Notes Marke Notas	Q.tà Q.ty Q.te M.ge C.ad
1	XH245100	Assieme carburatore	Carburetor assy	Carburateur complet	Vegaser kpl.	Carburador compl.		1
2	ED14230.30.64	Valvola gas	Throttle valve	Papillon de gaz	Drosselklappe	Valvulá		1
3	ED13680.10.808	Spillo conico	Needle	Pointeau conique	Kon. Nadel	Pasador cónico		1
4	ED14671.211.28	Polverizzatore	Fuel nozzle	Pulvérisateur	Einspritzdüse	Pulverizador		1
5	ED06413.76.02	Getto massimo	Main jet	Gicleur principal	Hauptdüse	Chiclé máximo		1
6	ED11600.34.02	Getto minimo	Idle jet	Gicleur minimum	Leerlaufdüse	Chiclé mínimo		1
7	ED13815.45.02	Getto avviamento	Starting jet	Gicleur de starter	Starterdüse	Chiclé arranque		1
8	EN0362.07.04	Manettino starter	Starter	Starter	Starter	Starter		1
9	ED14567.00.53	Coperchio	Cover	Couvercle	Deckel	Tapa		1
10	ED15020.00.61	Molla	Spring	Ressort	Feder	Resorte		1
11	ED13687.00.21	Bussola	Bushing	Douille	Buchse	Manguito		1
12	ED13681.00.21	Fermaglio	Retainer	Arret	Klammer	Abrazadera de sujeción		1
13	ED53009.00.78	Kit starter a filo	Kit starter cable	Kit du starter à cable	Draht-Starter-Satz	kit starter de cable		1
14	ED01411.00.61	Molla	Spring	Ressort	Feder	Resorte		1
15	ED14056.00.37	Vite regolazione minimo	Screw	Vis	Schraube	Tornillo		1
16	ED53029.00.78	Vite regolazione gas	Screw	Vis	Schraube	Tornillo		1
17	ED53053.00.78	Galleggiante	Float	Flotteur	Schwimmer	Flotador		1
18	ED13678.00.96	Vaschetta	Chamber	Cuvette	Becken	Cubeta		1
19	ED13709.00.36	Vite	Screw	Vis	Schraube	Tornillo		4
20	ED52622.00.77	Busta guarnizioni	Gasket set	Jeu joints	Dichtungssatz	Serie juntas		1
21	XH223402	Assieme trasmis. starter	Transmission-starter assy	Ensemble transmis. starter	Starter -übertraagungs-Satz	Conjunto transmisiòn starter		1

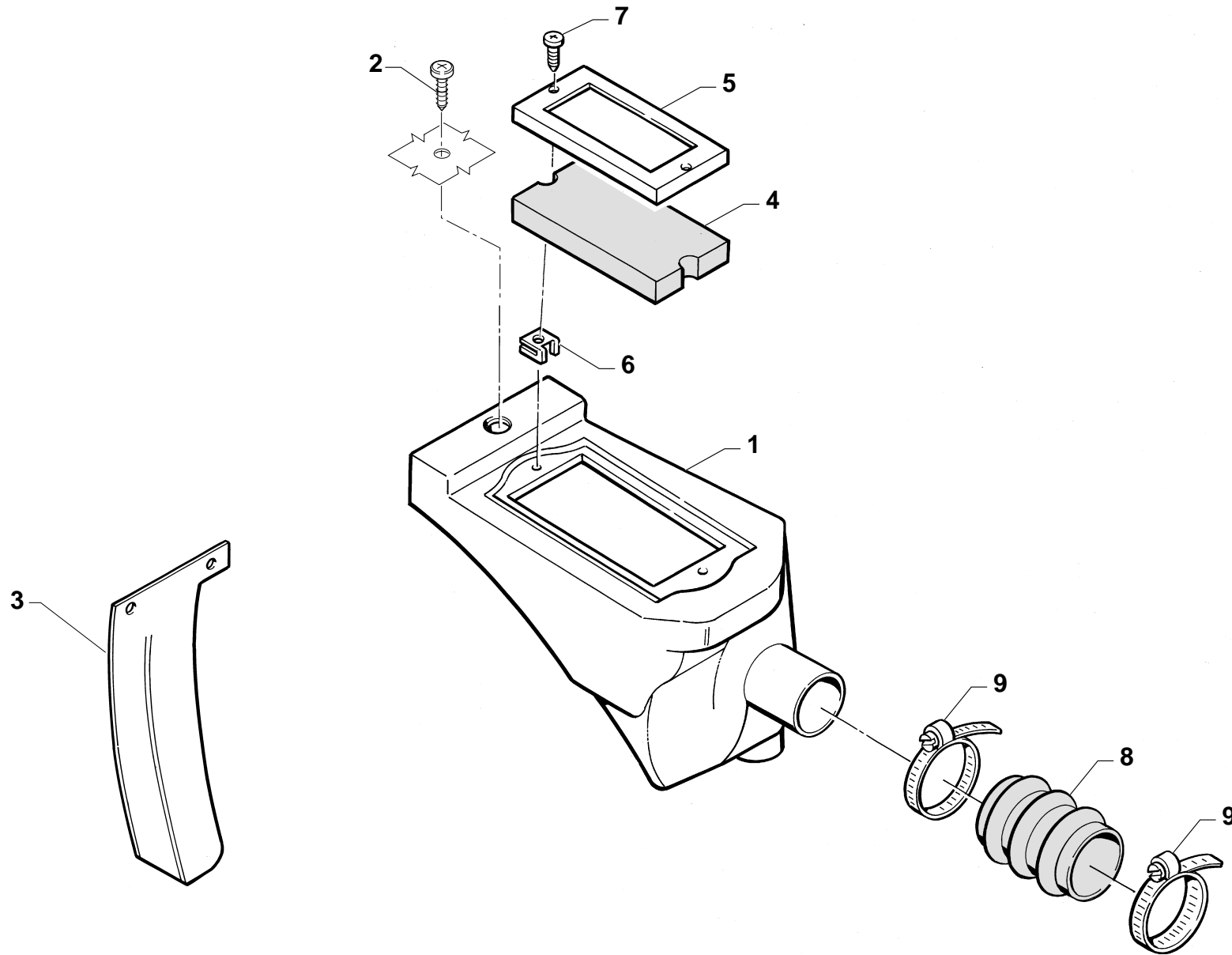

Pos. No. N. Index. Pos.	N.codice Code No. Nr. code Code Nr. N. cod.	Denominazione	Description	Désignation	Beschreibung	Descripción	Note Notes Notes Marke Notas	Q.tà Q.ty Q.te M.ge C.ad
1	XH236800	Scatola filtro	Air filter box	Boîte filtre	Filterkasten	Caja filtro aire		1
2	N1000710	Vite	Screw	Vis	Schraube	Tornillo		1
3	XH291900	Protezione	Guard	Protection	Schutz	Protección		1
4	XH236900	Filtro aspirazione	Filter	Filtre	Filter	Filtro		1
5	XH233300	Telaietto	Frame	Cadre	Cadre	Bastidor pequeño		1
6	N6002803	Dado a graffetta	Nut	Ecrou	Mutter	Tuerca		2
7	N1000406	Vite	Screw	Vis	Schraube	Tornillo		2
8	XH247600	Manicotto	Sleeve	Manchon	Muffe	Manguito		1
9	N1010401	Fascetta	Clamp	Collier	Schelle	Banda		2

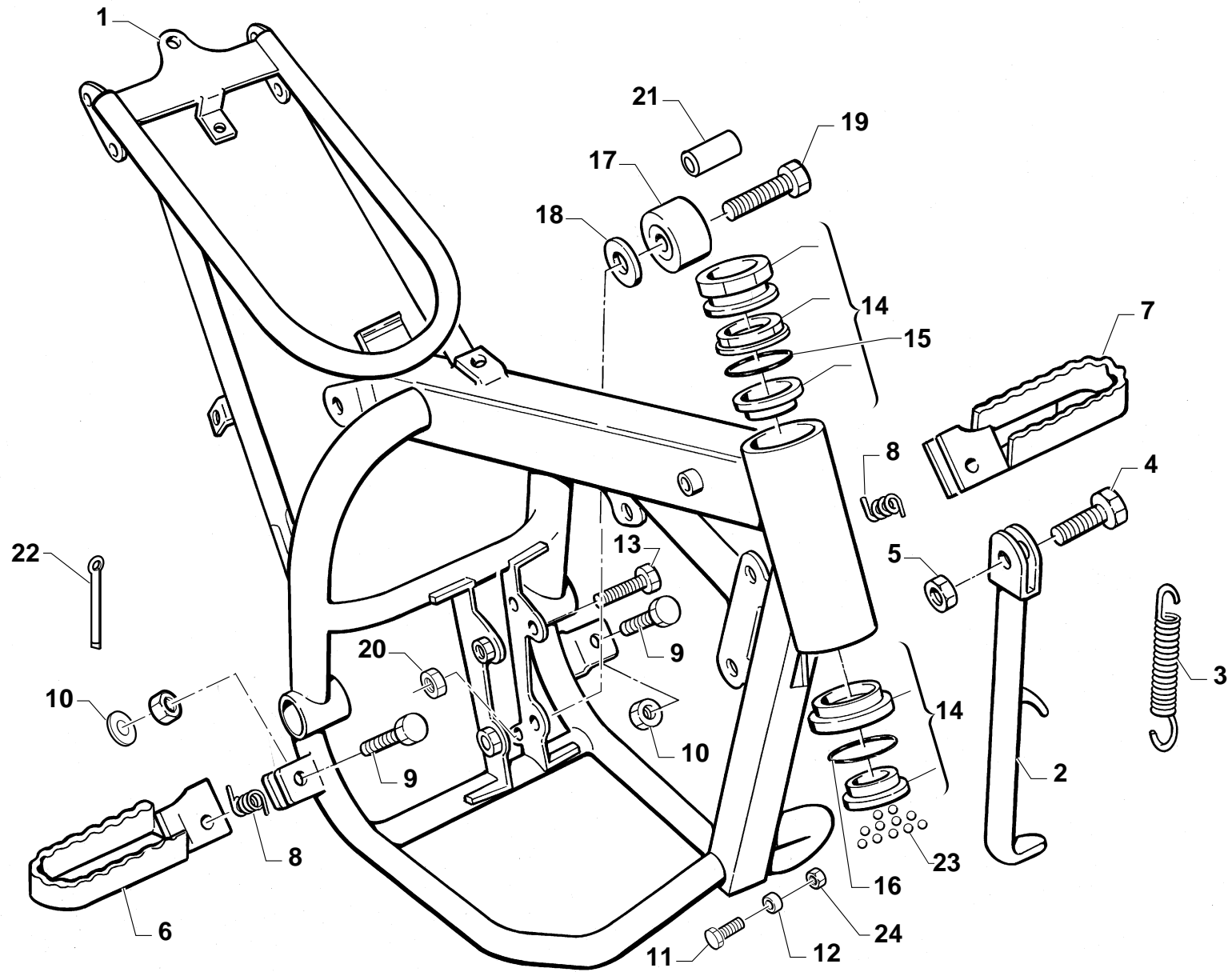

Pos. No. N. Index. Pos.	N.codice Code No. Nr. code Code Nr. N. cod.	Denominazione	Description	Désignation	Beschreibung	Descripción	Note Notes Notes Marke Notas	Q.tà Q.ty Q.te M.ge C.ad
1	XH3022A0	Telaio Verniciato	Painted frame	Cadre peint	Lackierter rahmen	Chasis pintado	507	1
1	XH2842A0	Telaio verniciato	Painted frame	Cadre peint	Lackierter rahmen	Chasis pintado	516	1
2	XH2371A3	Gamba laterale	Side stand	Bequille lat.	Seitenständer	Horquilla lateral		1
3	XH235000	Molla	Spring	Ressort	Feder	Resorte		1
4	N1000323	Vite	Screw	Vis	Schraube	Tornillo		1
5	N1002501	Dado	Nut	Ecrou	Mutter	Tuerca		1
6	XH3100A0	Ass. poggiapiedi DX	R. foot rest	Repose pied D.	R. Fussraste	Prisioneros der.		1
7	XH3099A0	Ass. poggiapiedi SX	L. foot rest	Repose pied G.	L. Fussraste	Prisioneros izq.		1
8	XH218300	Molla	Spring	Ressort	Feder	Resorte		2
9	N1000302	Vite	Screw	Vis	Schraube	Tornillo		2
10	N1001522	Rosetta	Washer	Rondelle	Scheibe	Arandela	516	2
10	N1002502	Dado	Nut	Ecrou	Mutter	Tuerca	507	2
11	N1000335	Vite motore ant.	Screw engine front	Vis	Schraube	Tornillo		1
12	XH238917	Distanziale	Spacer	Entretoise	Distanzstück	Separador		1
13	N1000305	Vite	Screw	Vis	Schraube	Tornillo		2
14	XH235800	Serie sterzo	Steering assy	Groupe direction	Reihe Lenker	Juego direccion	516	1
14	XH237300	Serie sterzo	Steering assy	Groupe direction	Reihe Lenker	Juego direccion	507	1
15	N0012001	Anello	Ring	Bague	Ring	Anillo	516	1
16	N0012007	Anello	Ring	Bague	Ring	Anillo	516	1
17	XH302600	Rullo catena	Chain roller	Aiguille	Rolle	Rodilo cadena		2
18	N1001503	Rosetta	Washer	Rondelle	Scheibe	Arandela		2
19	N1000305	Vite	Screw	Vis	Schraube	Tornillo		2
20	N1003003	Dado	Nut	Ecrou	Mutter	Tuerca		1
21	XH207911	Distanziale	Spacer	Entretoise	Distanzstück	Separador		2
22	N1012803	Copiglia	Split pin	Goupille	Splint	Clavija	516	2
23	N0016003	Sfera	Ball	Bille	Kugel	Esfera	516	26
24	N1003003	Dado	Nut	Ecrou	Mutter	Tuerca	507	1

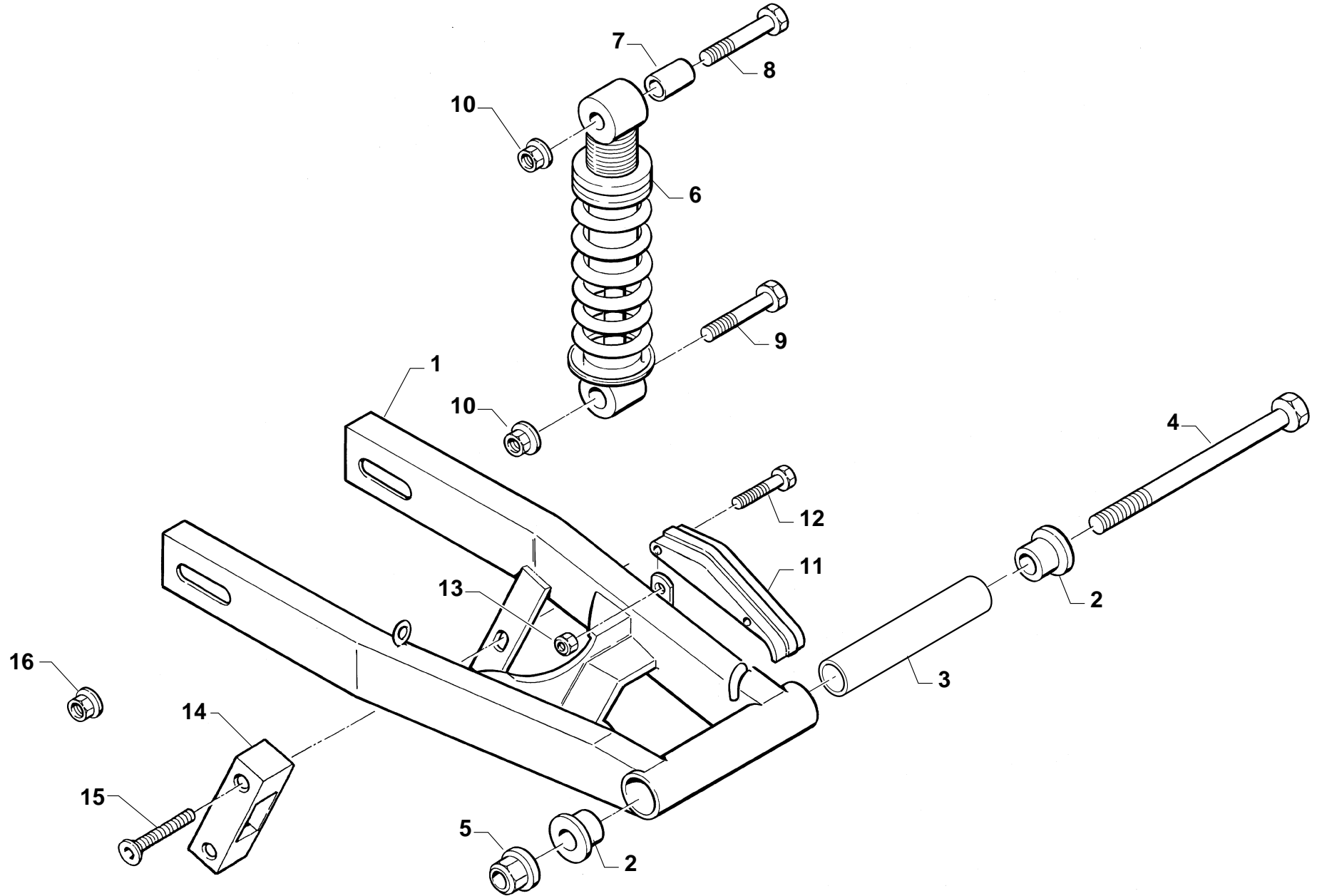

Pos. No. N. Index. Pos.	N.codice Code No. Nr. code Code Nr. N. cod.	Denominazione	Description	Désignation	Beschreibung	Descripción	Note Notes Notes Marke Notas	Q.tà Q.ty Q.te M.ge C.ad
1	XH3043A0	Forcellone post.	Big fork	Fourche	Radshwinge	Horquilla		1
2	XH232401	Boccola	Bush	Douille	Buchse	Casquillo		2
3	XH326400	Distanziale	Spacer	Entretoise	Distanzstück	Separador		1
4	N1000345	Vite	Screw	Vis	Schraube	Tornillo		1
5	N1002504	Dado	Nut	Ecrou	Mutter	Tuerca		1
6	XH304200	Ammortizzatore	Shock-absorber	Ammortisseur	Stossdämpfer	Amortiguador		1
7	XH238918	Distanziale	Spacer	Entretoise	Distanzstück	Separador		1
8	N1000308	Vite	Screw	Vis	Schraube	Tornillo		1
9	N1000317	Vite	Screw	Vis	Schraube	Tornillo		1
10	N1002504	Dado	Nut	Ecrou	Mutter	Tuerca		2
11	XH235601	Pattino catena	Chain slider	Glissière	Gleitbahn	Plato cadena		1
12	N1000322	Vite	Screw	Vis	Schraube	Tornillo		1
13	N1003006	Dado	Nut	Ecrou	Mutter	Tuerca		1
14	XH220500	Gomma guida catena post.	Chain slide	Galet chaine	Kettenrolle	Rodillo cadena		1
15	N1000101	Vite	Screw	Vis	Schraube	Tornillo		2
16	N1002502	Dado	Nut	Ecrou	Mutter	Tuerca		2

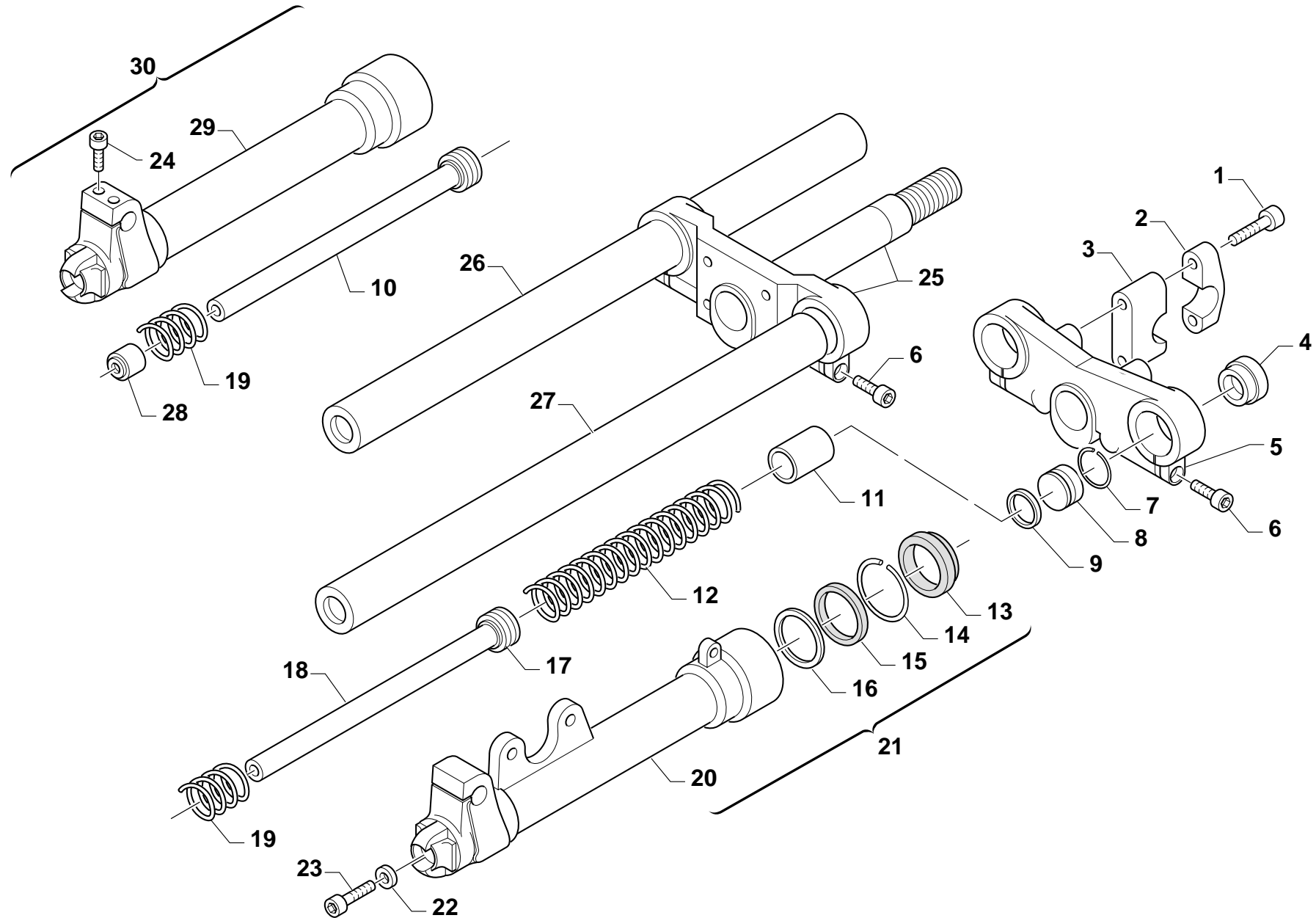

Pos. No. N. Index. Pos.	N.codice Code No. Nr. code Code Nr. N. cod.	Denominazione	Description	Désignation	Beschreibung	Descripción	Note Notes Notes Marke Notas	Q.tà Q.ty Q.te M.ge C.ad
1	ER520043AR	Vite	Screw	Vis	Schraube	Tornillo		4
2	ER505034A	Morsetto	Clamp	Etau	Klemme	Abrazadera		2
3	ER505033A	Base	Base	Socle	Lager	Base		2
4	ER532774	Tappo	Plug	Bouchon	Verschluss	Tapón		2
5	ER501443A	Testa di sterzo	Steering head	Tete direction	Lenkkopf	Cabezal de dirección		1
6	ER520001AR	Vite	Screw	Vis	Schraube	Tornillo		4
7	ER523277	Anello elastico	Ring	Bague	Ring	Aros de embolo		2
8	ER504148B	Tappo stelo	Plug	Bouchon	Verschluss	Tapón		2
9	ER528084	Anello	Ring	Bague	Ring	Anillo		2
10	ER803938A	Pompante DX	R.H. pumping element	Element de pompage D.	Pumpenelement, R.	Bombedora compl. DCHA		1
11	ER5181214	Tubetto	Pipe	Tuyau	Rohr	Tube		2
12	ER5141214	Molla	Spring	Ressort	Feder	Resorte		2
13	ER533297	Raschiapolvere	Dust scraper	Racloir poudre	Pulverabschaber	Rascador de polvo		2
14	ER523264	Anello elastico	Ring	Bague	Ring	Aros de embolo		2
15	ER528230	Anello tenuta	Seal	Anneu	Dichtring	Junta		2
16	ER522166AA	Rondella	Washer	Rondelle	Scheibe	Arandela		2
17	ER524157	Segmento	Circlip	Segment	Kolbenring	Segmento		1
18	ER803936A	Pompante SX	L.H. pumping element	Element de pompage D.	Pumpenelement, L.	Bombedora completa IZQ.		1
19	ER5141015	Contromolla	Return spring	Ressort de rappel	Gegenfeder	Resorte antagonista		2
20	ER5031528A	Gamba SX	L.H. stem	Tige gauche	Linker Schaft	Vaeilla IZQ.		1
21	ER5031528AR	Gamba SX compl.	L.H. fork leg assy	Fourche complete G.	Telegabel Kpl. L.	Horquilla izq. compl.		1
22	ER522225	Rondella	Washer	Rondelle	Scheibe	Arandela		2
23	ER520001	Vite	Screw	Vis	Schraube	Tornillo		2
24	ER520276AR	Vite	Screw	Vis	Schraube	Tornillo		2
25	ER7051050	Base di sterzo con perno	Steering crown with pin	Socle de direction avec pivot	Gabelbrücke mit Bolzen	Base de dirección con perno		1
26	ER708196/R	Tubo portante SX	Pipe	Tuyau	Rohr	Tube		1
27	ER708197/R	Tubo portante DX	Pipe	Tuyau	Rohr	Tube		1
28	ER512068	Tampone	Pad	Tampon	Stopfen	Tampón		2
29	ER5031527A	Gamba DX	R.H. stem	Tige D.	Rechter Schaft	Vaeilla der.		1
30	ER5031527A/R	Gamba DX compl.	R.H. fork leg assy	Fourche complete D.	Telegabel Kpl. R.	Horquilla derech. compl.		1

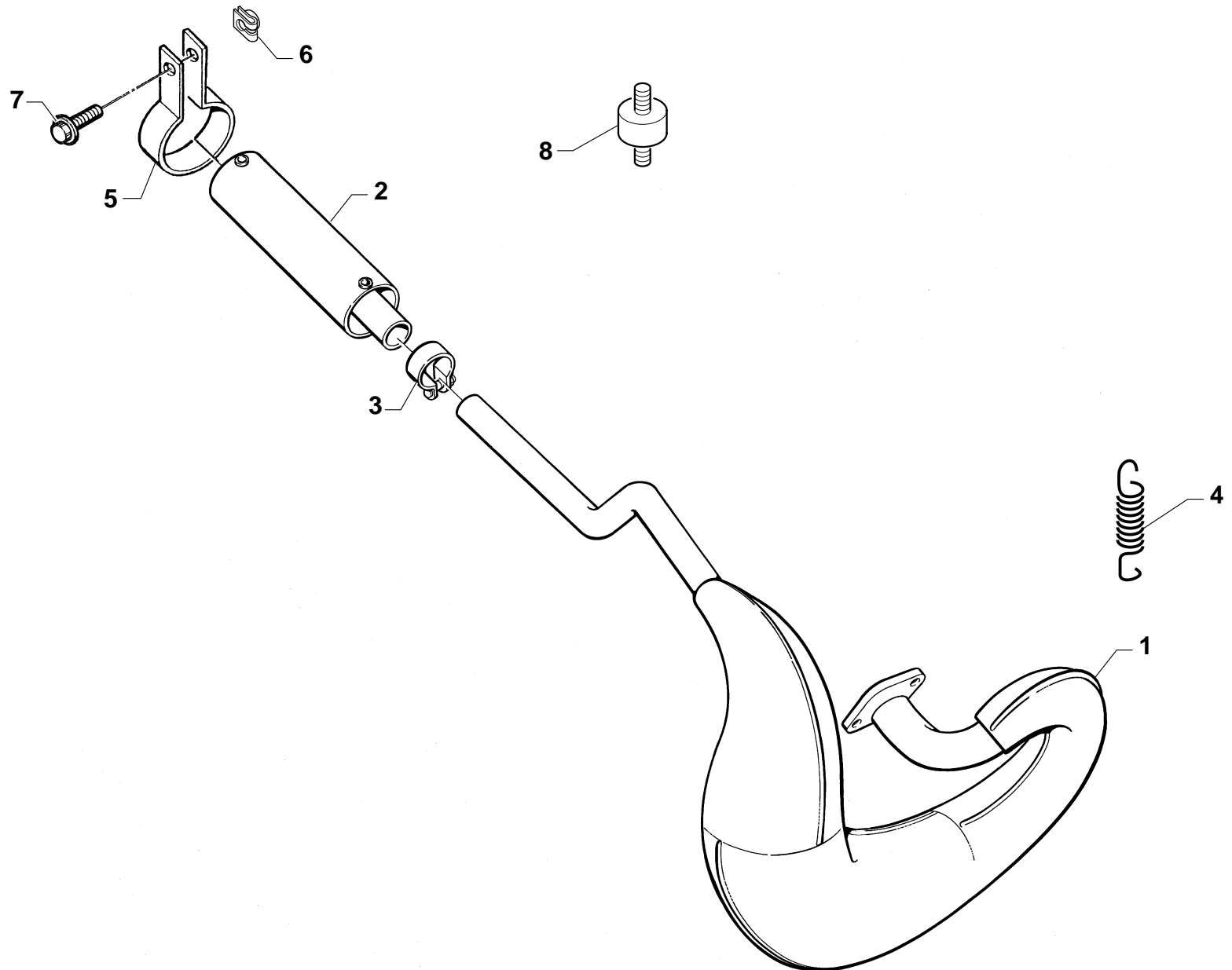

Pos. No. N. Index. Pos.	N.codice Code No. Nr. code Code Nr. N. cod.	Denominazione	Description	Désignation	Beschreibung	Descripción	Note Notes Notes Marke Notas	Q.tà Q.ty Q.te M.ge C.ad
1	XH3236A0	Tubo di scarico	Exhaust pipe	Tuyauterie	Leitung	Tuberia		1
2	XH275200	Silenziatore di scarico	Exhaust silencer	Silencieux d'échappement	Schalldämpfer	Silenciador de escape		1
3	N2010201	Fascetta	Clamp	Collier	Schelle	Banda		1
4	XH301600	Molla	Spring	Ressort	Feder	Resorte		2
5	N2010301	Fascetta	Clamp	Collier	Schelle	Banda		1
6	N6002802	Dado a graffetta	Nut	Ecrou	Mutter	Tuerca		1
7	N1000303	Vite	Screw	Vis	Schraube	Tornillo		1
8	N0017602	Antivibrante	Silent-block	Antivibration	Schwingungsdämpfer	Anti-vibrador		2

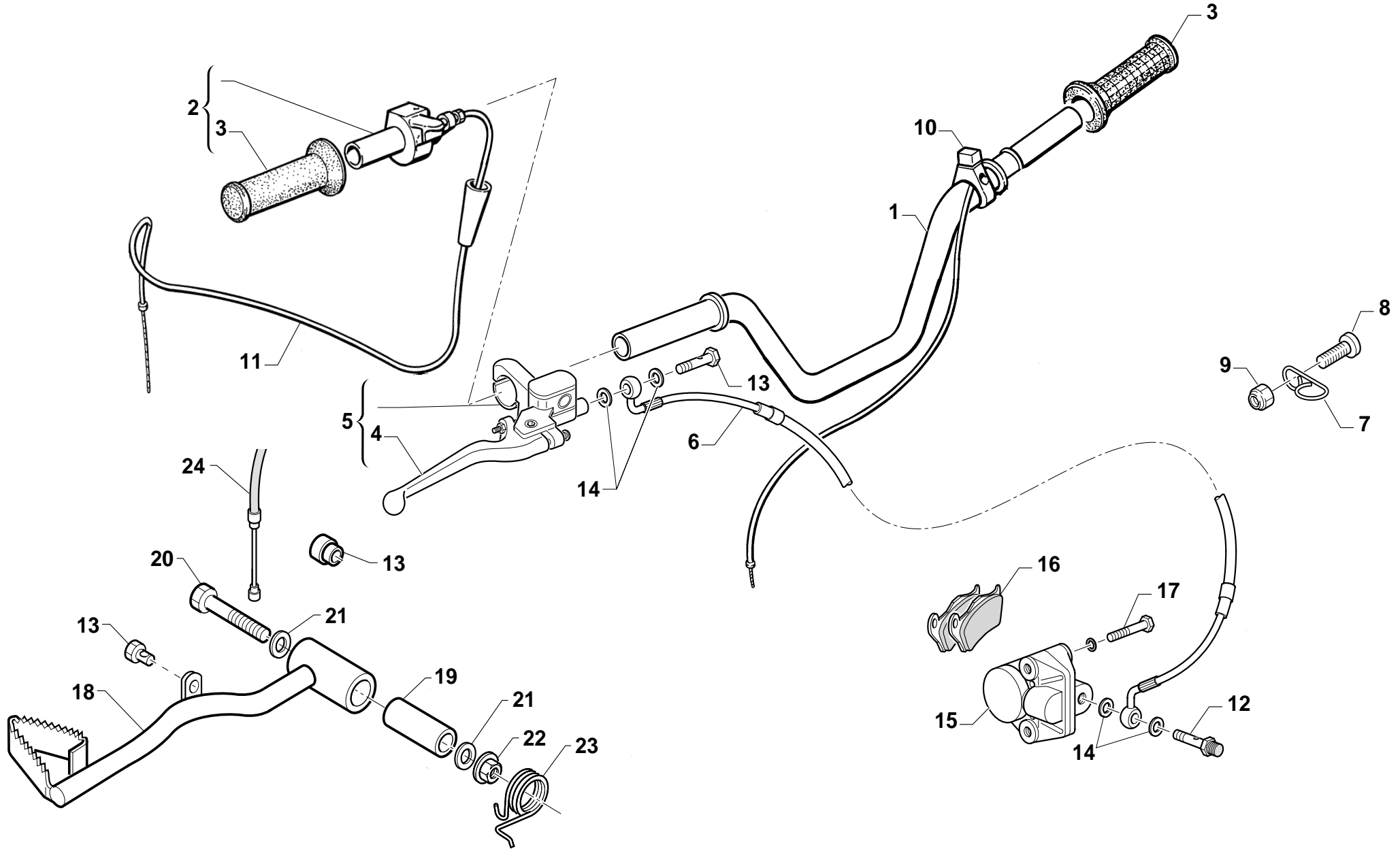

Pos. No. N. Index. Pos.	N.codice Code No. Nr. code Code Nr. N. cod.	Denominazione	Description	Désignation	Beschreibung	Descripción	Note Notes Notes Marke Notas	Q.tà Q.ty Q.te M.ge C.ad
1	XH2460A0	Manubrio	Hanblebar	Guidon	Lenker	Manillar		1
2	XH218500	Comando gas con manopole	Throttle control	Comm.gaz	Gasgriff	Mando gas		1
3	XH244900	Coppia manopole	Grip pair	Couple poignées	Griffpaar	Pareja manoplas		1
4	EJ134.76.010C	Leva freno anteriore	Front brake lever	Levier frein avant	Vorderer Bremshebel	Palanca freno delantero		1
5	XH286000	Comando freno anteriore	Front brake control	Comande frein av.	Bremshebel Vorderradbr.	Mando freno ant.		1
6	XH287900	Tubo freno anteriore	Trasmiss.front brake	Trasmission frein av.	Bremsseil Vorderradbr	Trasmis.fr.del.		1
7	XH245601	Anello	Ring	Bague	Ring	Anillo		1
8	N1000902	Vite	Screw	Vis	Schraube	Tornillo		1
9	N1002505	Dado	Nut	Ecrou	Mutter	Tuerca		2
10	XH244800	Pulsante di massa	Push	Pulsant	Druckknopf	Pulsador		1
11	XH224002	Trasmissione comando gas	Gas control trasmiss	Trasmiss. comm. gaz	Gaszug	Trasmis.m. gas		1
12	EJ190.00.001C	Vite raccordo con sfiato	Screw	Vis	Schraube	Tornillo		1
13	N0011003	Nottolino	Pawl	Cliquet	Klinke	Pestillo		1
14	EJ190.99.095	Rosetta	Washer	Rondelle	Scheibe	Arandela		4
15	XH286200	Pinza freno	Brake caliper	Etrier frein	Bremssattel	Pinza		2
16	EJ290.99.074	Pastiglie	Pads	Plaquettes	Bremsbelafpaar	Pastillas		2
17	N1000714	Vite	Screw	Vis	Schraube	Tornillo		2
18	XH3046A0	Pedale freno	Brake pedal	Pedale	Fusshebel	Pedal		1
19	XH244400	Bussola	Bushing	Douille	Buchse	Manguito		1
20	N1000319	Vite	Screw	Vis	Schraube	Tornillo		1
21	N1001503	Rosetta	Washer	Rondelle	Scheibe	Arandela		1
22	N1002501	Dado	Nut	Ecrou	Mutter	Tuerca		1
23	XH305500	Molla	Spring	Ressort	Feder	Resorte		1
24	XH225203	Trasmissione freno post.	Rear brake trasmission	Trasmission frein arriere	Bremsseil Hinterradbr	Trasmission freno trasero		1

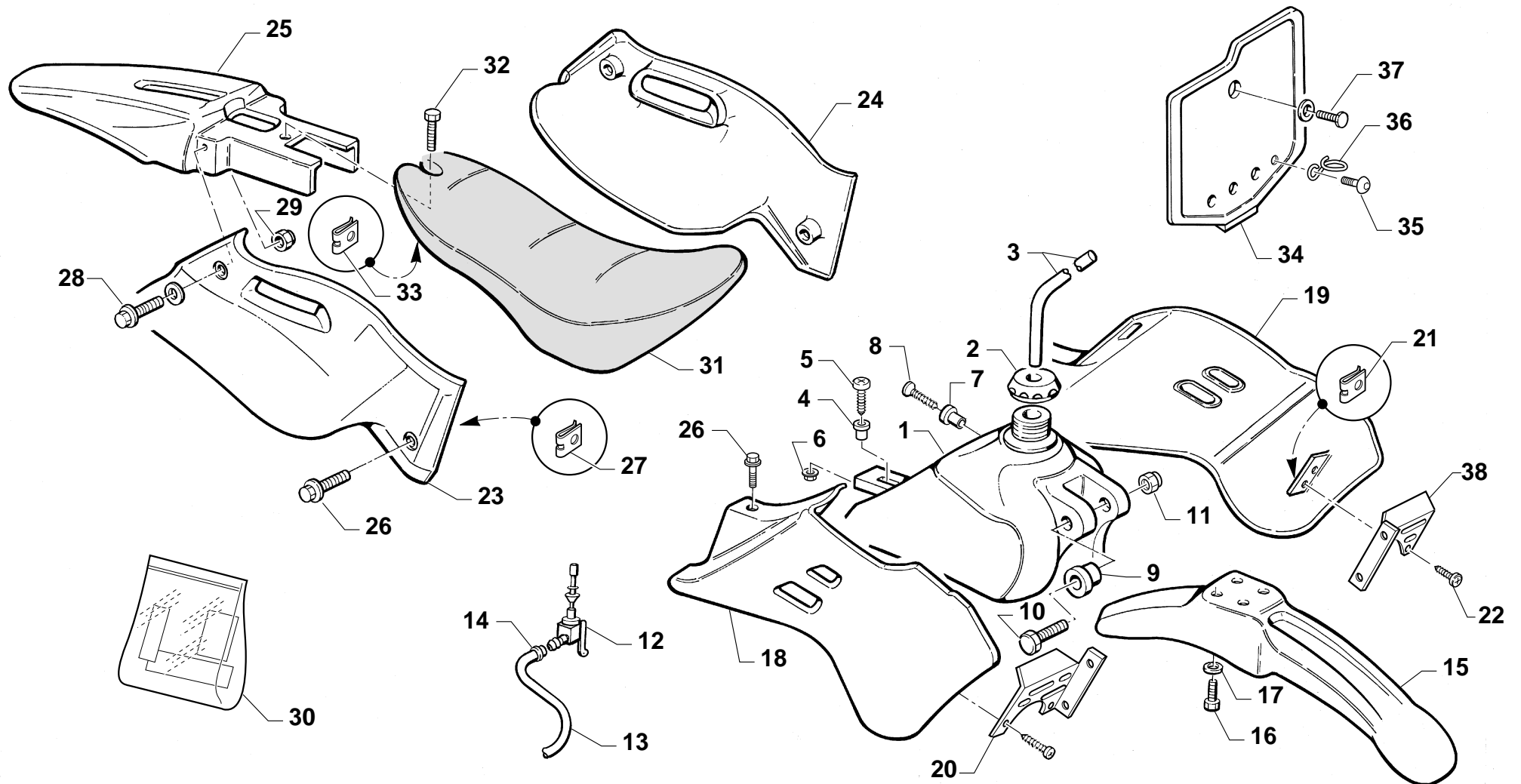

Pos. No. N. Index. Pos.	N.codice Code No. Nr. code Code Nr. N. cod.	Denominazione	Description	Désignation	Beschreibung	Descripción	Note Notes Notes Marke Notas	Q.tà Q.ty Q.te M.ge C.ad
1	XH222400	Serbatoio	Fuel tank	Réservoir	Kraftstoffbehälter	Dep. carburante		1
2	XH222500	Tappo	Plug	Bouchon	Verschluss	Tapón		1
3	N0011501	Tubo di sfiato	Pipe	Tuyau	Rohr	Tubo		1
4	XH236701	Bussola	Bushing	Douille	Buchse	Manguito		1
5	N1000302	Vite	Screw	Vis	Schraube	Tornillo		1
6	N6002802	Dado a graffetta	Nut	Ecrou	Mutter	Tuerca		1
7	XH223900	Distanziale	Spacer	Entretoise	Distanzstück	Separador		1
8	N1000103	Vite	Screw	Vis	Schraube	Tornillo		1
9	XH236700	Bussola	Bushing	Douille	Buchse	Manguito		2
10	N1000204	Vite	Screw	Vis	Schraube	Tornillo		1
11	N1003001	Dado	Nut	Ecrou	Mutter	Tuerca		1
12	XH222800	Rubinetto benzina	Fuel cock	Robinet de combustible	Kraftstoffhahn	Llave de paso gasolina		1
13	N0011502	Tubo benzina	Pipe	Tuyau	Rohr	Tubo		1
14	N3010001	Fascetta	Clamp	Collier	Schelle	Banda		2
15	XH2208A0	Parafango ant.	Front mudguard	Garde-boue avant	Vord. Kotfluegel	Guarda-barros delantero		1
16	N1000705	Vite	Screw	Vis	Schraube	Tornillo		4
17	N1001502	Rosetta	Washer	Rondelle	Scheibe	Arandela		4
18	XH2210A0	Pannello ant. DX	RH. front panel	Panneau av. D.	Vordere rechte Verkeid	Panel del. der.	507	1
18	XH3234A0	Pannello ant. DX	RH. front panel	Panneau av. D.	Vordere rechte Verkeid	Panel del. DER.	516	1
19	XH2211A0	Pannello ant. SX	L.H. front panel	Panneau av. G.	Vordere linke Verkeid	Panel del. IZQ.	507	1
19	XH3235A0	Pannello anteriore SX	L.H. front panel	Panneau av. G.	Vordere linke Verkeid	Panel del. IZQ.	516	1
20	XH245800	Griglia-DX	R.H. grille	Grille D.	Gitter RTS.	Parilla der.		1
21	N6002801	Dado a graffetta	Nut	Ecrou	Mutter	Tuerca		4
22	N1000401	Vite	Screw	Vis	Schraube	Tornillo		4
23	XH2213A1	Fianchetto post. DX	Rear right valance panel	Capot ar.d.	Hint.rechtes seintenteil	Costado post. DCHA		1
24	XH2214A1	Fianchetto post. SX	Rear left valance panel	Capot ar.g.	Hint.linkses seintenteil	Costado post. IZQ		1
25	XH2472C0	Parafango post.	Rear mudguard	Garde-boue ar.	Hinterradkotflügel	Guardabarros tras.		1
26	N1000710	Vite	Screw	Vis	Schraube	Tornillo		2
27	N6002802	Dado a graffetta	Nut	Ecrou	Mutter	Tuerca		2
28	N1000714	Vite	Screw	Vis	Schraube	Tornillo		2
29	N1002502	Dado	Nut	Ecrou	Mutter	Tuerca		2
30	XH292200	Kit decalco	Transfer kit	Kit autocollant	Satz Abziehbilder	Kit decalco	507	1
30	XH328700	Kit decalco	Transfer kit	Kit autocollant	Satz Abziehbilder	Kit decalco	516	1
31	XH2223A2	Sella	Seat	Siège	Sattel	Sillín		1
32	N1000709	Vite	Screw	Vis	Schraube	Tornillo		1
33	N6002802	Dado a graffetta	Nut	Ecrou	Mutter	Tuerca		1
34	XH2209B0	Portanumero	Num. holder	Porte num.	Nummerhalter	Portanumero		1
35	N1000718	Vite	Screw	Vis	Schraube	Tornillo		1
36	XH245600	Anello	Ring	Bague	Ring	Anillo		1
37	N1000901	Vite	Screw	Vis	Schraube	Tornillo		1
38	XH245700	Griglia-SX	L.H. grille	Grille G.	Gitter L.	Parilla IZQ.		1

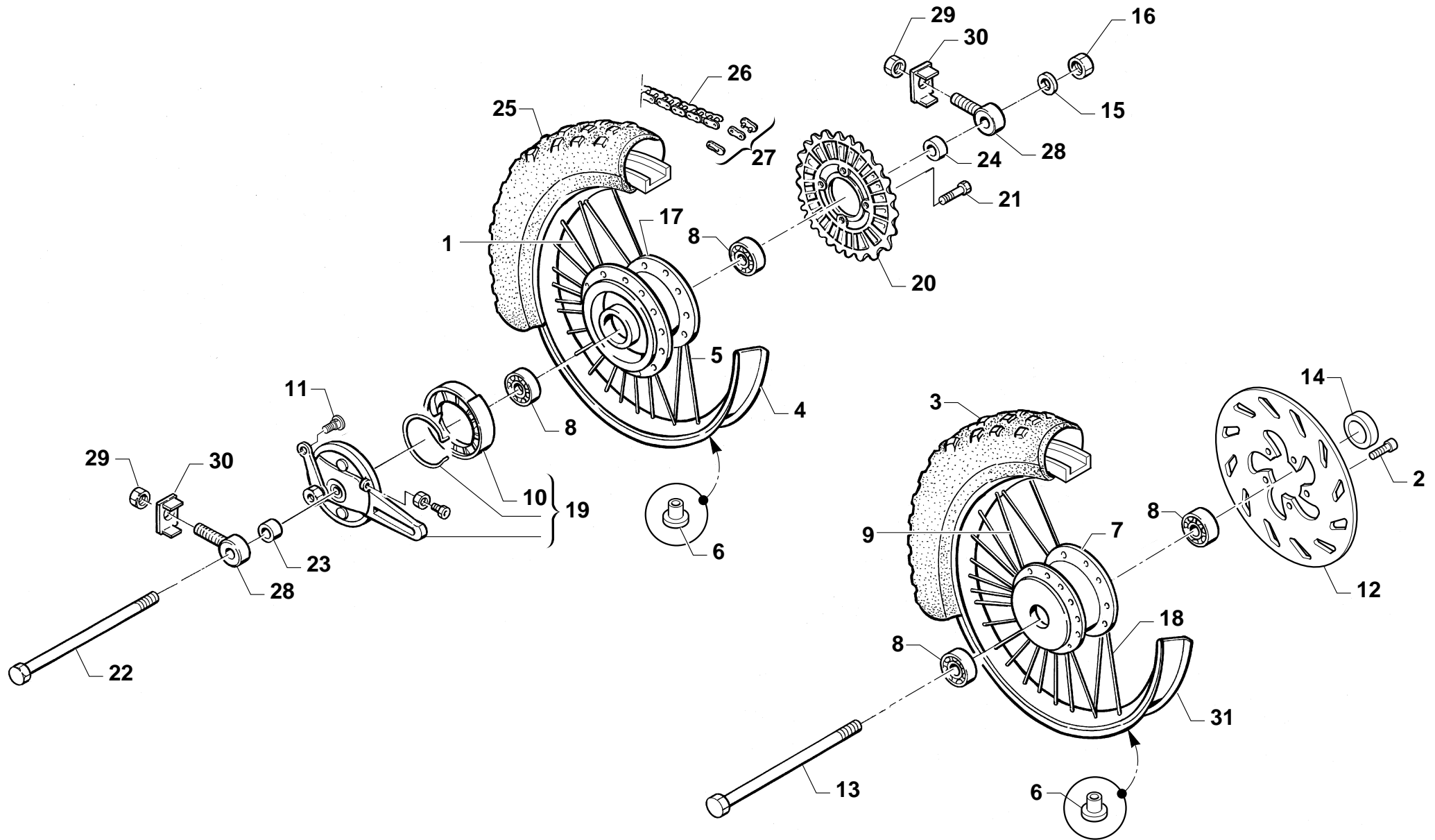

Pos. No. N. Index. Pos.	N.codice Code No. Nr. code Code Nr. N. cod.	Denominazione	Description	Désignation	Beschreibung	Descripción	Note Notes Notes Marke Notas	Q.tà Q.ty Q.te M.ge C.ad
1	N2007918	Raggio DX	R.H. spoke	Bras D	Speiche R	Radio DER		14
2	N1000207	Vite	Screw	Vis	Schraube	Tornillo		5
3	N0005508	Pneumatico	Tyre	Pneu	Reifen	Neumático		1
4	N3004503	Cerchio post. acciaio	Rim	Jante	Felge	Llanta	507	1
4	N3004803	Cerchio post. alluminio	Rim	Jante	Felge	Llanta	516	1
5	N2007917	Raggio SX	L.H. spoke	Bras G	Speiche L	Radio IZQ		14
6	N2007502	Nipplo	Nipple	Nipple	Nippel	Nipple		56
7	XH243300	Mozzo	Hub	Moyeau	Radnabe	Cubo		1
8	N0003502	Cuscinetto	Bearing	Roulement	Lager	Cojinete		4
9	N2007902	Raggio DX	R.H. spoke	Bras D	Speiche R	Radio DER		14
10	XH295500	Assieme ceppi con molle	Complete blake bloks	Sabots de frein complets	Komplete bremsbacke	Mordaza compl.		1
11	EI.MT.03570501	Vite	Screw	Vis	Schraube	Tornillo		1
12	XH282900	Disco freno anteriore	Brake disc	Disque frein	Bremsscheibe	Disco freno		1
13	XH286700	Perno ruota anteriore	Pin	Pivot	Bolzen	Perno ruoda		1
14	XH238901	Distanziale	Spacer	Entretoise	Distanzstück	Separador		1
15	N1001514	Rosetta	Washer	Rondelle	Scheibe	Arandela		2
16	N1002602	Dado	Nut	Ecrou	Mutter	Tuerca		1
17	XH288800	Mozzo	Hub	Moyeau	Radnabe	Cubo		1
18	N2007901	Raggio SX	L.H. spoke	Bras G	Speiche L	Radio IZQ		14
19	XH295600	Coperchio portaceppi	Cover	Couvercle	Deckel	Tapa		1
20	XH288703	Corona	Ring gear	Couronne	Kranz	Corona		1
21	N1000303	Vite	Screw	Vis	Schraube	Tornillo		5
22	XH239004	Perno ruota	Pin	Pivot	Bolzen	Perno		1
23	XH238905	Distanziale	Spacer	Entretoise	Distanzstück	Separador		1
24	XH238920	Distanziale	Spacer	Entretoise	Distanzstück	Separador		1
25	N0005509	Pneumatico post.	Reae tyre	Pneu	Reifen	Neumático		1
26	N0009010	Catena	Chain	Chaîne	Kette	Cadena		1
27	N0009106	Giunto	Coupling	Joint	Kupplung	Junta		1
28	XH232500	Tendicatena	Chain adjuster	Tendeur de chaine	Kettenspanner	Tensor de cadena		2
29	N1003003	Dado	Nut	Ecrou	Mutter	Tuerca		2
30	XH232600	Piastrina	Plate	Plaquette	Plättchen	Placa		2
31	N3004504	Cerchio ant. acciaio	Rim	Jante	Felge	Llanta	507	1
31	N3004802	Cerchio	Rim	Jante	Felge	Llanta	516	1

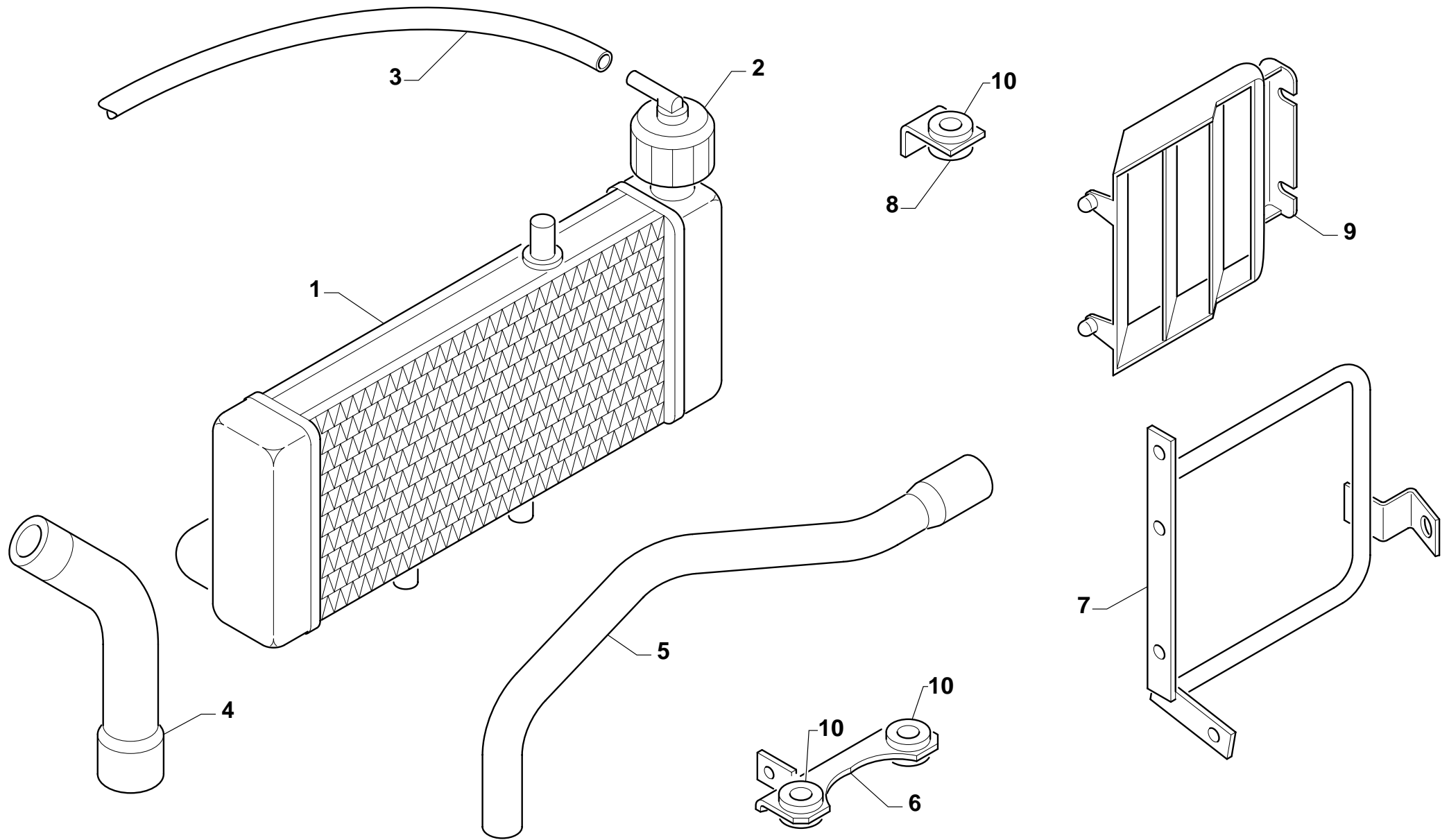

Pos. No. N. Index. Pos.	N.codice Code No. Nr. code Code Nr. N. cod.	Denominazione	Description	Désignation	Beschreibung	Descripción	Note Notes Notes Marke Notas	Q.tà Q.ty Q.te M.ge C.ad
1	XH285300	Radiatore	Radiator	Radiateur	Kuehler	Radiator		1
2	TP50806	Tappo radiatore	Plug	Bouchon	Verschluss	Tapón		1
3	N0011507	Tubo sfiato	Pipe	Tuyau	Rohr	Tubo		1
4	XH306800	Tubo testa/radiatore	Rubber pipe radiator/head	Tuyau	Rohr	Tubo		1
5	XH306900	Tubo radiatore/pompa	Rubber pipe radiator/pump	Tuyau	Rohr	Tubo		1
6	XH299800	Piastrina inferiore	Plate down	Plaque	Plättchen	Placa		2
7	XH3073A0	Coppia telaietto	Mast	Chassis	Mast	Bastidor		1
8	XH312200	Piastrina	Plate	Plaque	Plättchen	Placa		2
9	XH304900	Griglia DX-SX	R.H.-L.H.grille	Grille D-G	Gitter R-L	Parilla DER-IZQ		2
10	N0011301	Gommino	Rubber pad	Pièce caoutchouc	Gummistück	Junta de goma		1