



CATALOGO RICAMBI
SPARE PARTS CATALOG
CATALOGUE PIECES DE RECHANGE
ERZATZ TEILKATALOG
CATALOGO PIEZAS DE REPUESTOS



CH 510 BASIC BIG WHEELS
CH 511 RACING BIG WHEELS
ED. 05/2003 REV.00

INFORMAZIONI GENERALI

Nelle ordinazioni indicare:

- 1) Il modello e il numero di matricola del motociclo, stampigliato sul canotto di sterzo.
- 2) Il numero di codice dei particolari seguito dalla descrizione.

GENERAL INFORMATION

When ordering specify:

- 1) The motorcycle's model and serial number, stamped on the steering head.;
- 2) The part's code number followed by its description;

INFORMATIONS GENERALES

Les commandes doivent être passées en indiquant:

- 1) Le modèle et le numéro matricule de la moto, estampillés sur la tige du guidon.
- 2) Le numéro de code des pièces détachées suivi de leur description;

ALLGEMEINE HINWEISE

Bei Ersatzbestellung ist folgendes anzugeben:

- 1) Der Modell und die Seriennummer des Motorrads, die am Lenkrohr eingeprägt ist.
- 2) Die Bestellnummer der Ersatzteile mit der entsprechenden Beschreibung.

INFORMACIONES GENERALES

En los pedidos se debe indicar:

- 1) El modelo y el número de serie de la motocicleta, grabados en el tubo de dirección.
- 2) El número de código de la parte y a continuación la descripción;

Modello

Model
Medele
Model
Modelo

N° di serie Telaio

Chassis serial number
N° de série du châssis
Serien-Nummer des Rahmen
Numero chasis



Pos.

No
N.
Index
Pos.

N codice.

Code No.
Nr. code
Code Nr
N. cod.

Denominazione

Description
Designation
Bezeichnung
Denominación

CH 510 - CH 511 Ed. 05/03 Rev. 00 TAVOLA - DRAWING
TABLE - BILD - TABLA **1**

CH 510 - CH 511 TAVOLA - DRAWING
TABLE - BILD - TABLA **1**

ACCESSORI OPZIONALI - OPTIONAL ACCESSORIES - ACCESSOIRES EN OPTION
OPTIONALE ZUBEHÖRE - ACCESORIOS EN OPCION

Pos. No. N. Index. Pos.	N.codice Code No. Nr. code Code Nr. N. cod.	Denominazione	Description	Désignation	Beschreibung	Descripción	Note Notes Notes Marka Notas	Q.ta Q.ty Q.te M.ge C.ad
1	XH2481.00	Maniglia	Handle	Poignée	Handgriff	Manilla		1
2	XH2480.00	Valvola	Valve	Soupape	Ventil	Válvula		1

INDICE – INDEX – INDEX – INHALTSVERZEICHNIS - INDICE

Tavola
Drawing
Table
Bild
Tabla

	Denominazione	Description	Designation	Bezeichnung	Denominacion	Pag
1	ACCESSORI OPZIONALI	OPTIONAL ACCESSORIES	ACCESSOIRES EN OPTION	OPTIONALE ZUBEHÖRE	ACCESORIOS EN OPCIÓN	5
2	MOTORE	ENGINE	MOTEUR	MOTORS	MOTOR	7
3	MOTORE	ENGINE	MOTEUR	MOTORS	MOTOR	9
4	MOTORE	ENGINE	MOTEUR	MOTORS	MOTOR	11
4A	MOTORE	ENGINE	MOTEUR	MOTORS	MOTOR	13
5	MOTORE	ENGINE	MOTEUR	MOTORS	MOTOR	15
5A	MOTORE	ENGINE	MOTEUR	MOTORS	MOTOR	17
6	MOTORE	ENGINE	MOTEUR	MOTORS	MOTOR	19
6A	MOTORE	ENGINE	MOTEUR	MOTORS	MOTOR	21
7	MOTORE	ENGINE	MOTEUR	MOTORS	MOTOR	23
7A	MOTORE	ENGINE	MOTEUR	MOTORS	MOTOR	25
8	CARBURATORE	CARBURETOR	CARBURATEUR	VERGASER	CARBURADOR	27
8A	CARBURATORE	CARBURETOR	CARBURATEUR	VERGASER	CARBURADOR	29
9	FILTRO ARIA	AIR FILTER	FILTRE AIRE	AIRFILTER	FILTRO DE AIRE	31
10	TELAIO, PEDANE	FRAME, FOOT RESTS	ADRE, REPOSE PIEDS	RAHMEN-FUSSBRETT	BASTIDOR, REPOSAPIES	33
11	FORCELLONE E SOSP. POSTERIORE	SWING ARM AND	FOURCHE ET SUSPENSION	GABEL UND	HORQUILLA Y SUSPENSION	35
12	SOSPENSIONE ANTERIORE	FRONT FORK ASSEMBLY	SUSPENSION AVANT	VORDERTELESKOPGABEL	SUSPENSION DELANTERA	37
12A	SOSPENSIONE ANTERIORE	FRONT FORK ASSEMBLY	SUSPENSION AVANT	VORDERTELESKOPGABEL	SUSPENSION DELANTERA	39
13	SCARICO	EXHAUST SYSTEM	TUYAU D'ECHAPPEMENT	AUSPUFFROHR	TUBO DE ESCAPE	41
14	MANUBRIO E COMANDI	HANDLEBAR AND CONTROLS ...	GUIDON ET COMMANDES	LENKER UND STEUERORGANE ..	MANILLAR Y MANDOS	43
14A	MANUBRIO E COMANDI	HANDLEBAR AND CONTROLS ...	GUIDON ET COMMANDES	LENKER UND STEUERORGANE ..	MANILLAR Y MANDOS	45
15	CARENATURE E PARAFANGHI	FAIRING AND MUDGUARD	CARENATURE ET GARDE-BOUE	HINTERSCHALE UND KOTFLUEGEL.	CARROCERIA Y GUARDA-BARROS...	47
16	RUOTA ANTERIORE,	FRONT WHEEL,	ROUE AV., ROUE	VORTERRAD,	HINTERRAD, RUEDA	49
	RUOTA POSTERIORE	REAR WHELL	ARRIÈRE	RUEDA DELANTERA	TRASERA	49
16A	RUOTA ANTERIORE,	FRONT WHEEL,	ROUE AV., ROUE	VORTERRAD,	HINTERRAD, RUEDA	51
	RUOTA POSTERIORE	REAR WHELL	ARRIÈRE	RUEDA DELANTERA	TRASERA	51

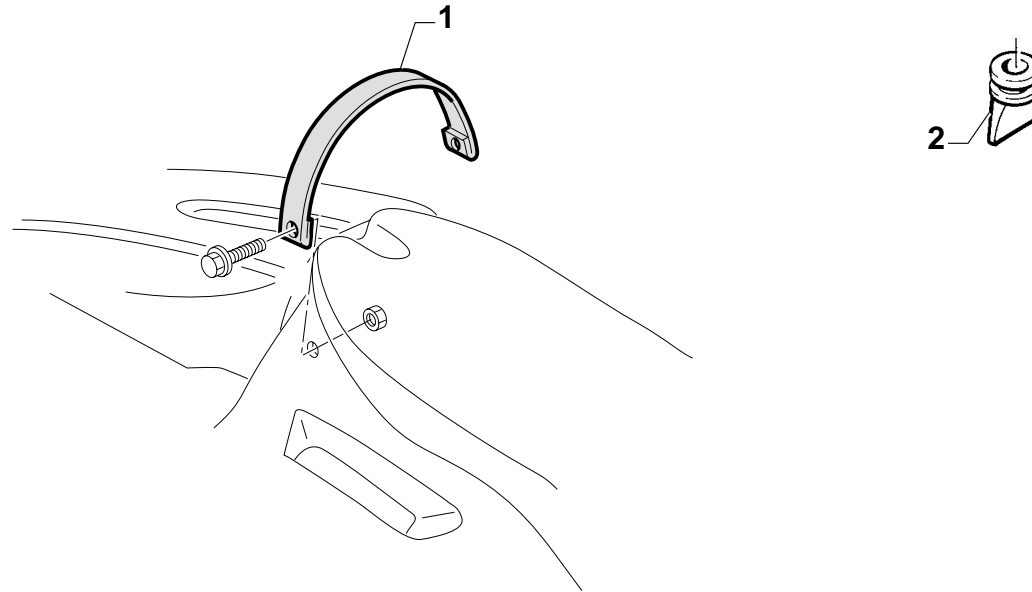

Pos. No. N. Index. Pos.	N.codice Code No. Nr. code Code Nr. N. cod.	Denominazione	Description	Désignation	Beschreibung	Descripción	Note Notes Notes Marke Notas	Q.tà Q.ty Q.te M.ge C.ad
1	XH248100	Maniglia	Handle	Poignée	Handgriff	Manilla		1
2	XH248000	Valvola	Valve	Soupape	Ventil	Válvula		1

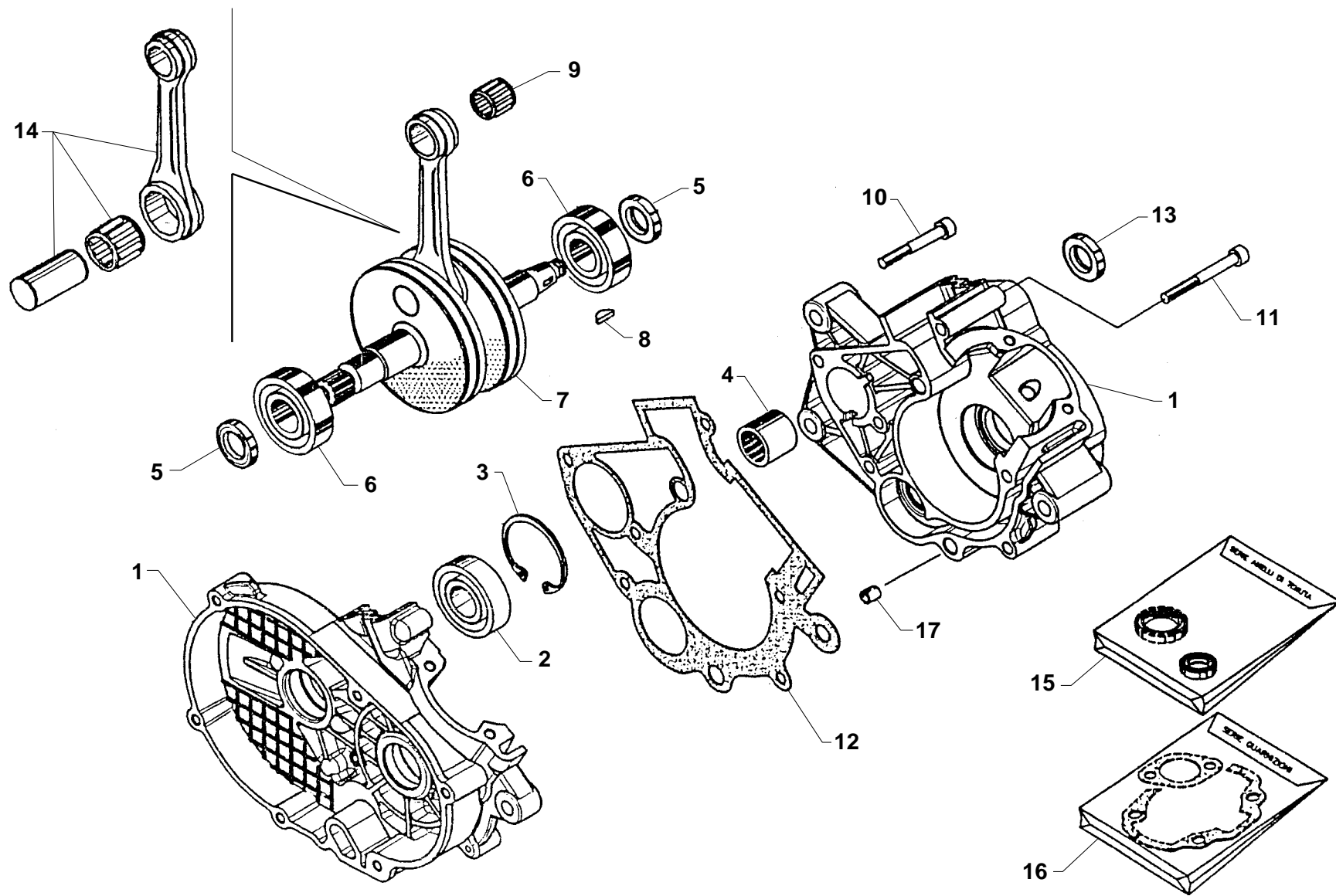

Pos. No. N. Index. Pos.	N.codice Code No. Nr. code Code Nr. N. cod.	Denominazione	Description	Désignation	Beschreibung	Descripción	Note Notes Notes Marke Notas	Q.tà Q.ty Q.te M.ge C.ad
1	EM1206.90	Carter	Complete carter	Carter	Gehaeuse	Càrter		1
2	EM1260.67	Cuscinetto	Bearing	Roulement	Lager	Cojinete		1
3	EM1050.70	Anello elastico	Ring	Bague	Ring	Aros de embolo		1
4	EM1085.12	Astuccio	Needle bearing	Etui	Buechse	Estuche		1
5	EM1060.33	Anello tenuta	Seal	Anneu	Dichtring	Junta		2
6	EM1260.21	Cuscinetto	Bearing	Roulement	Lager	Cojinete		2
7	EM1001.87	Albero motore	Shaft	Arbre	Welle	Ciguenal	510	1
7	EM1001.89	Albero motore	Shaft	Arbre	Welle	Ciguenal	511	1
8	EM1270.25	Chiavetta	Key	Clavette	Keil	Clave		1
9	EM1610.24	Gabbia	Cage	Cage	Lagerkcafig	Jaula		1
10	EM2919.93	Vite	Screw	Vis	Schraube	Tornillo	510	1
11	EM2919.91	Vite	Screw	Vis	Schraube	Tornillo		7
12	EM1642.97	Guarnizione	Gasket	Garnitue	Dichtung	Junta		1
13	EM1060.34	Anello	Ring	Bague	Ring	Anillo		1
14	EM1100.40	Biella completa	Con.rod	Bielle	Pleuel	Biela	510	1
14	EM1100.41	Biella completa	Con.rod	Bielle	Pleuel	Biela	511	1
15	EM2605.36	Serie anelli	Rings set	Serie bagues	Ringsatz	Serie de aros	510	1
16	EM2606.55	Serie guarnizioni	Gasket set	Jeu joints	Dichtungssatz	Serie juntas	510	1
16	EM2606.57	Serie guarnizioni	Gasket set	Jeu joints	Dichtungssatz	Serie juntas	511	1
17	EM2681.27	Spina	Pin	Goupille	Stift	Clavija		2

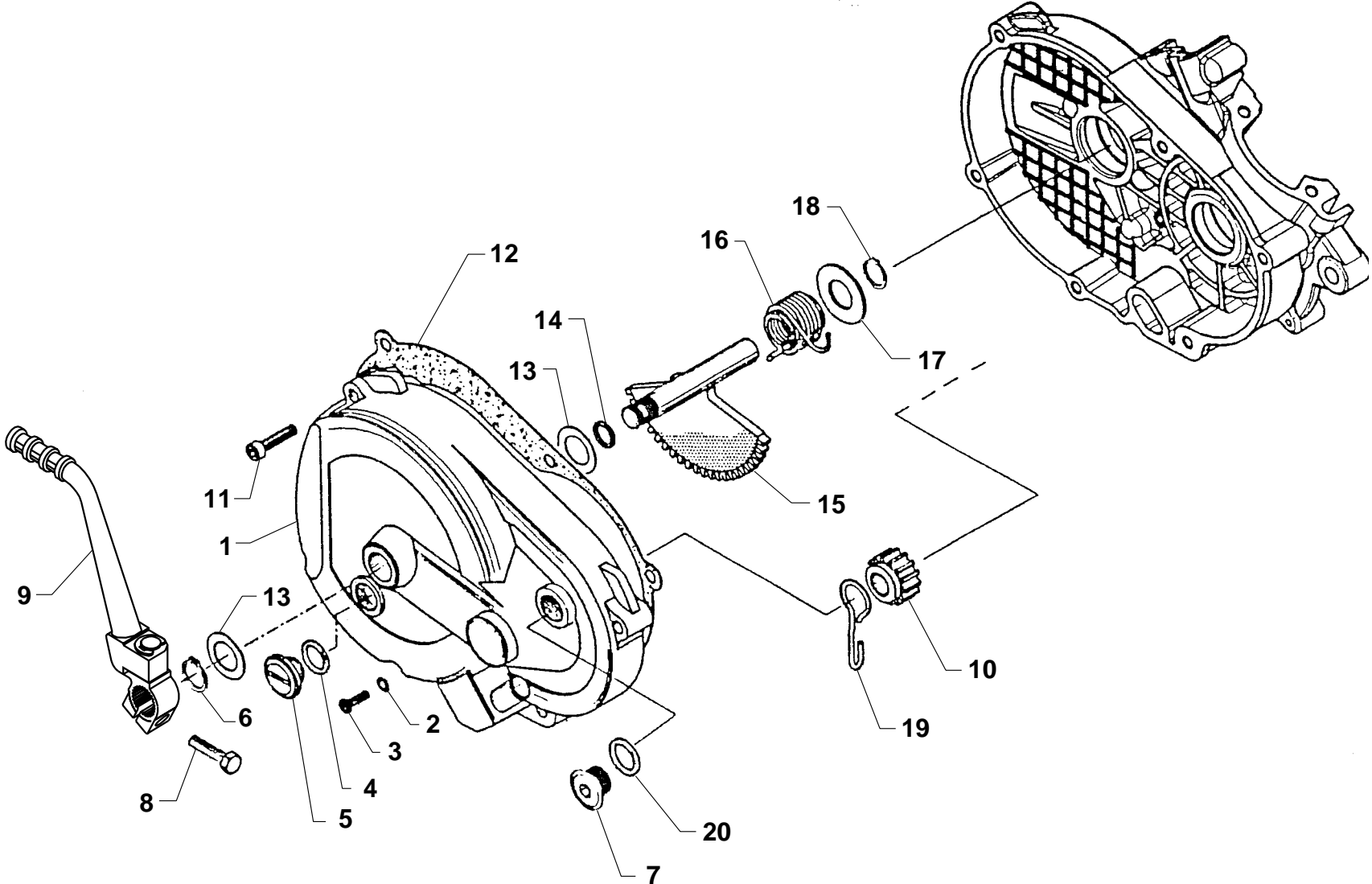

Pos. No. N. Index. Pos.	N.codice Code No. Nr. code Code Nr. N. cod.	Denominazione	Description	Désignation	Beschreibung	Descripción	Note Notes Notes Marke Notas	Q.tà Q.ty Q.te M.ge C.ad
1	EM1242.57	Coperchio	Cover	Couvercle	Deckel	Tapa	510	1
1	EM1242.76	Coperchio	Cover	Couvercle	Deckel	Tapa	511	1
2	EM1640.69	Guarnizione	Gasket	Garnitue	Dichtung	Junta		1
3	EM2961.44	Vite	Screw	Vis	Schraube	Tornillo		1
4	EM1640.26	Guarnizione	Gasket	Garnitue	Dichtung	Junta		1
5	EM2730.07	Tappo	Plug	Bouchon	Verschluss	Tapón		1
6	EM1050.53	Anello	Ring	Bague	Ring	Anillo		1
7	EM2730.46	Tappo	Plug	Bouchon	Verschluss	Tapón		1
8	EM2919.85	Vite	Screw	Vis	Schraube	Tornillo		1
9	EM1900.52	Leva	Lever	Levier	Hebel	Palanca		1
10	EM1813.00	Ingranaggio	Gear	Engrenage	Zahnrad	Engranaje		1
11	EM2919.87	Vite	Screw	Vis	Schraube	Tornillo		6
12	EM1642.96	Guarnizione	Gasket	Garnitue	Dichtung	Junta		1
13	EM2540.0508	Rondella	Washer	Rondelle	Scheibe	Arandela		2
14	EM1070.24	Anello	Ring	Bague	Ring	Anillo		1
15	EM1001.88	Albero	Shaft	Arbre	Welle	Eje		1
16	EM2011.81	Molla	Spring	Ressort	Feder	Resorte		1
17	EM2540.10	Rondella	Washer	Rondelle	Scheibe	Arandela		1
18	EM1050.01	Anello	Ring	Bague	Ring	Anillo		1
19	EM2011.97	Molla	Spring	Ressort	Feder	Resorte		1
20	EM1640.09	Guarnizione	Gasket	Garnitue	Dichtung	Junta		1

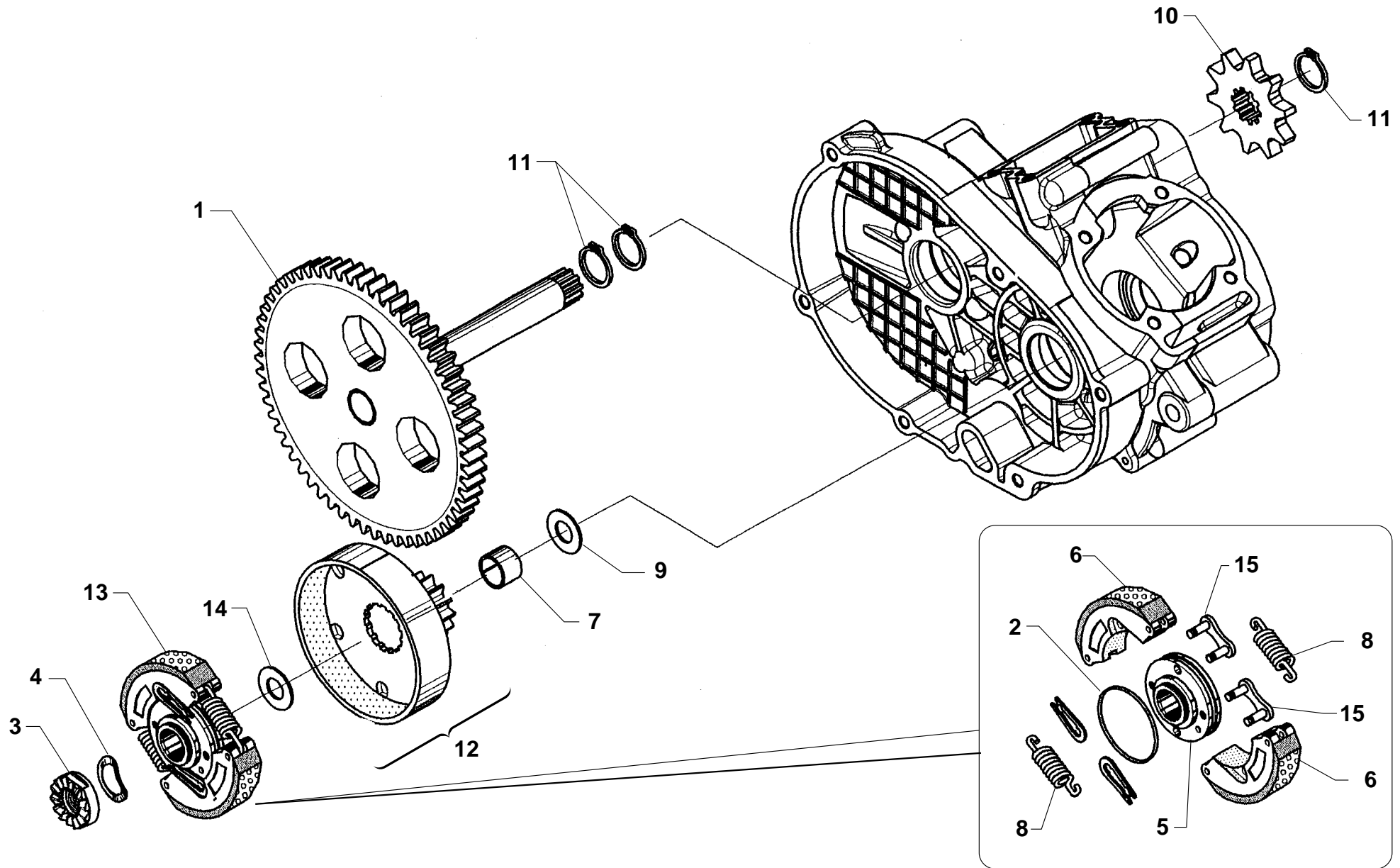

Pos. No. N. Index. Pos.	N.codice Code No. Nr. code Code Nr. N. cod.	Denominazione	Description	Désignation	Beschreibung	Descrpción	Note Notes Notes Marke Notas	Q.tà Q.ty Q.te M.ge C.ad
1	EM1206.89	Corona	Ring gear	Couronne	Kranz	Corona		1
2	EM1070.65	Anello	Ring	Bague	Ring	Anillo		1
3	EM1310.35	Dado	Nut	Ecrou	Mutter	Tuerca		1
4	EM2011.95	Molla	Spring	Ressort	Feder	Resorte		1
5	EM2060.87	Mozzo	Hub	Moyeau	Radnabe	Cubo		1
6	EM1273.52	Ceppo	Block	Segment de frein	Bremsbacke	Cepo		2
7	EM1150.97	Boccola	Bush	Douille	Buchse	Casquillo		1
8	EM2011.30	Molla	Spring	Ressort	Feder	Resorte		2
9	EM2540.0506	Rondella	Washer	Rondelle	Scheibe	Arandela		1
10	EM2326.08	Pignone	Pinion	Pignon	Ritzel	Piñón		1
11	EM1050.35	Anello	Ring	Bague	Ring	Anillo		3
12	EM1800.31	Ingranaggio	Gear	Engrenage	Zahnrad	Engranaje		1
13	EM2000.90	Mozzo	Hub	Moyeau	Radnabe	Cubo		1
14	EM1361.30	Distanziale	Spacer	Entretoise	Distanzstück	Separador		1
15	EM1205.58	Congiunzione per ceppi	Block junction	Accoupl. segm. de frein	Bremsbacken verbindung	Conjunción cecos		2

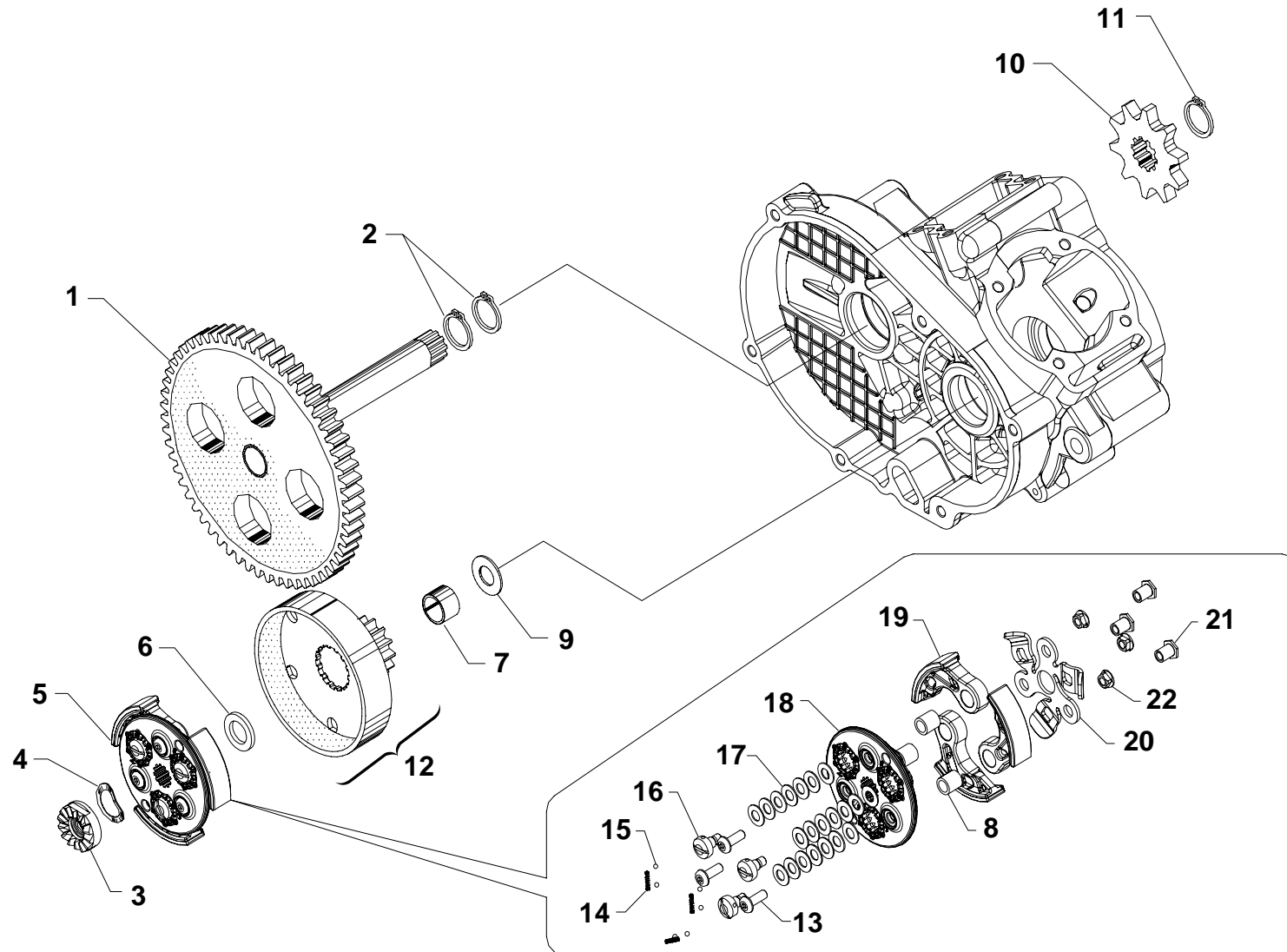

Pos. No. N. Index. Pos.	N.codice Code No. Nr. code Code Nr. N. cod.	Denominazione	Description	Désignation	Beschreibung	Descripción	Note Notes Notes Marke Notas	Q.tà Q.ty Q.te M.ge C.ad
1	EM1207.22	Corona	Ring gear	Couronne	Kranz	Corona		1
2	EM1050.35	Anello	Ring	Bague	Ring	Anillo		2
3	EM1310.35	Dado	Nut	Ecrou	Mutter	Tuerca		1
4	EM2011.95	Molla	Spring	Ressort	Feder	Resorte		1
5	EM1500.95	Frizione	Clutch	Embrayage	Kupplung	Embrague		1
6	EM1361.30	Distanziale	Spacer	Entretoise	Distanzstück	Separador		1
7	EM1150.97	Boccola	Bush	Douille	Buchse	Casquillo		1
8	EM1151.02	Boccola	Bush	Douille	Buchse	Casquillo		3
9	EM2540.0506	Rondella	Washer	Rondelle	Scheibe	Arandela		1
10	EM2326.08	Pignone	Pinion	Pignon	Ritzel	Piñón		1
11	EM1050.35	Anello	Ring	Bague	Ring	Anillo		1
12	EM180031	Ingranaggio	Gear	Engrenage	Zahnrad	Engranaje		1
13	EM296126	Vite	Screw	Vis	Schraube	Tornillo		3
14	EM2011.86	Molla	Spring	Ressort	Feder	Resorte		3
15	EM2682.41	Sfera	Ball	Bille	Kugel	Esfera		6
16	EM296127	Vite	Screw	Vis	Schraube	Tornillo		3
17	EM2011.96	Molla	Spring	Ressort	Feder	Resorte		21
18	EM2371.42	Piattello	Plate	Plateau	Teller	Placa		1
19	EM2000.92	Massetta	Masselotte	Fliehgewicht	Weight	Contrapeso		3
20	EM2011.84	Molla	Spring	Ressort	Feder	Resorte		1
21	EM2140.13	Nottolino	Pawl	Cliquet	Klinke	Pestillo		3
22	EM2771.58	Tenditore	Turnbuckle	Tendeur	Spanner	Tensor		3

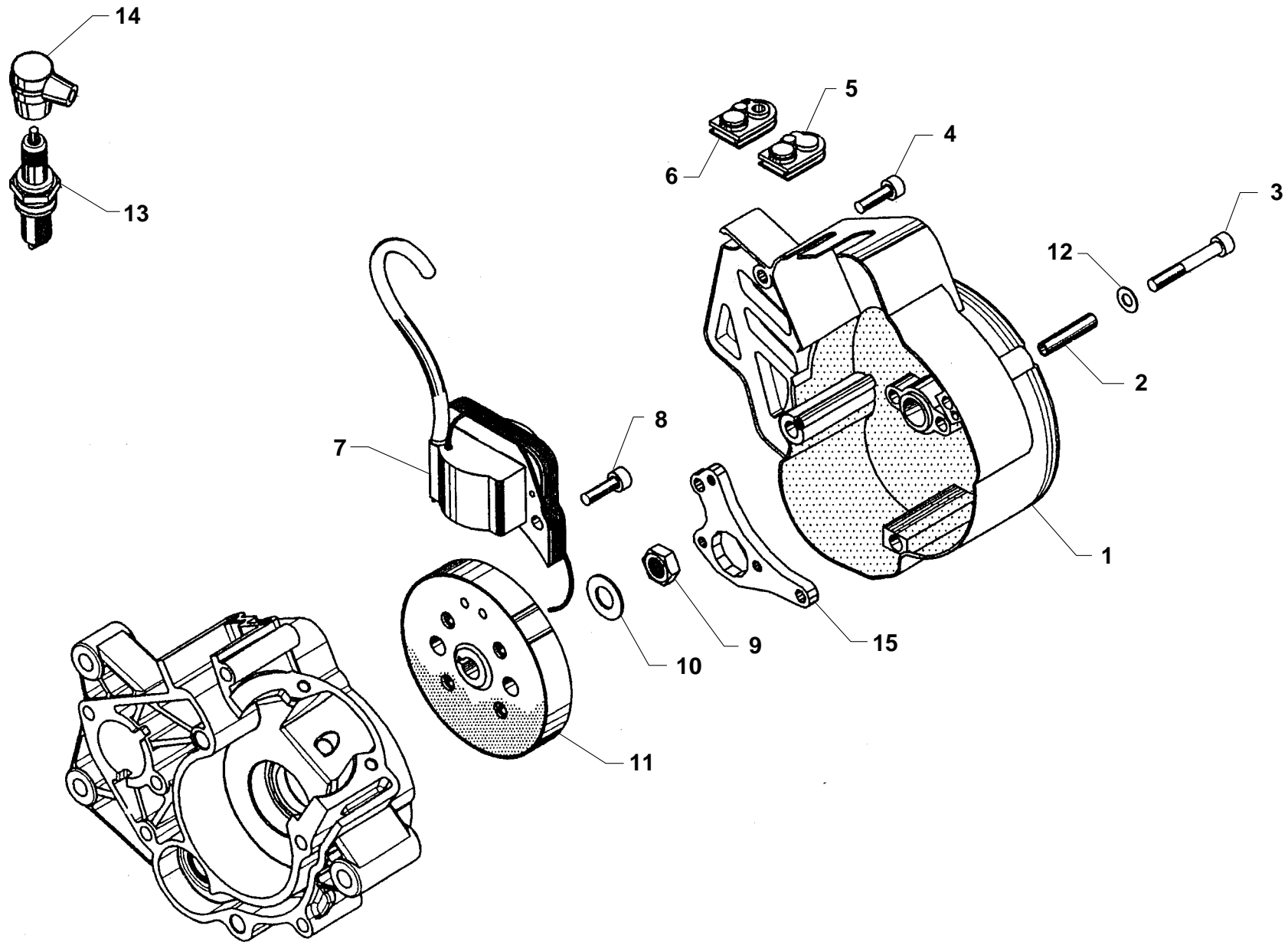

Pos. No. N. Index. Pos.	N.codice Code No. Nr. code Code Nr. N. cod.	Denominazione	Description	Désignation	Beschreibung	Descripción	Note Notes Notes Marke Notas	Q.tà Q.ty Q.te M.ge C.ad
1	EM1242.60	Volano	Flywheel	Volant	Schwungmasse	Volante		1
2	EM1670.56	Grano elastico	Dowel	Goujon	Stift	Clavija		2
3	EM2919.66	Vite	Screw	Vis	Schraube	Tornillo		3
4	EM2919.59	Vite	Screw	Vis	Schraube	Tornillo		1
5	EM1630.75	Gommino	Rubber pad	Pièce caoutchouc	Gummistück	Junta de goma		2
6	EM1630.78	Gommino	Rubber pad	Pièce caoutchouc	Gummistück	Junta de goma		1
7	EM1400.03	Bobina	Coil	Bobine	Zündspule	Bobina		1
8	EM2919.57	Vite	Screw	Vis	Schraube	Tornillo		2
9	EM1310.32	Dado	Nut	Ecrou	Mutter	Tuerca		1
10	EM2540.23	Rondella	Washer	Rondelle	Scheibe	Arandela		1
11	EM2901.61	Volano	Flywheel	Volant	Schwungmasse	Volante		1
12	EM2542.40	Rondella	Washer	Rondelle	Scheibe	Arandela		4
13	EM1272.83	Candela	Spark plug	Bougie	Zündkerze	Bujía		1
14	EM2371.52	Pipetta	Pipette	Pipette	Pipette	Pipa		1
15	EM2682.57	Staffa	Bracket	Etrier	Buegel	Brida		1

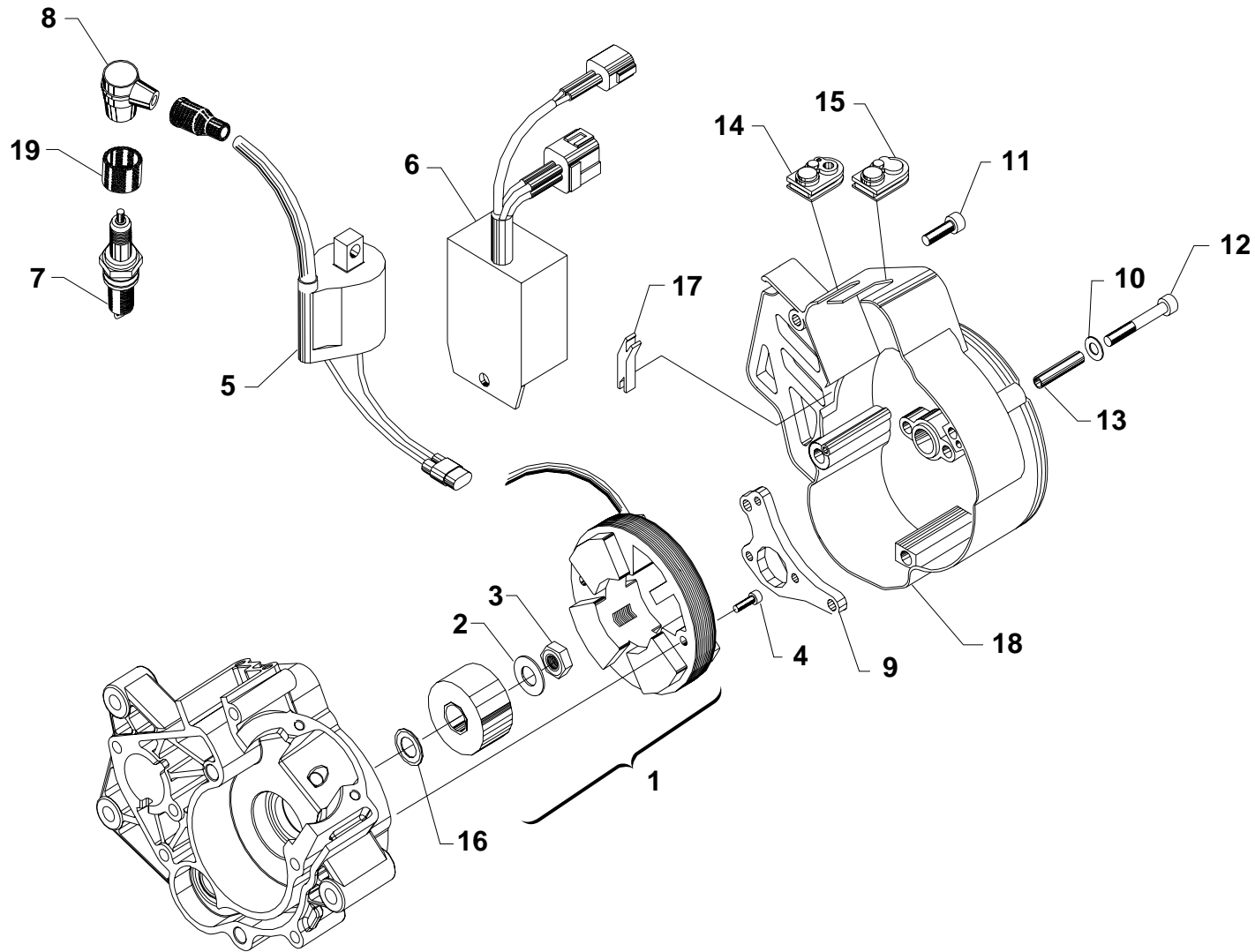

Pos. No. N. Index. Pos.	N.codice Code No. Nr. code Code Nr. N. cod.	Denominazione	Description	Désignation	Beschreibung	Descripción	Note Notes Notes Marke Notas	Q.tà Q.ty Q.te M.ge C.ad
1	EM2901.59	Volano	Flywheel	Volant	Schwungmasse	Volante		1
2	EM2540.23	Rondella	Washer	Rondelle	Scheibe	Arandela		1
3	EM1310.27	Dado	Nut	Ecrou	Mutter	Tuerca		1
4	EM2919.33	Vite	Screw	Vis	Schraube	Tornillo		2
5	EM1400.04	Bobina	Coil	Bobine	Zündspule	Bobina		1
6	EM1410.72	Centralina	Hydraul.attach.	Dispos.hydraul.	Hydr.einheit	Controller		1
7	EM1273.48	Candela	Spark plug	Bougie	Zündkerze	Bujía		1
8	EM2371.46	Pipetta	Pipette	Pipette	Pipette	Pipa		1
9	EM2682.57	Staffa	Bracket	Etrier	Buegel	Brida		1
10	EM2542.40	Rondella	Washer	Rondelle	Scheibe	Arandela		4
11	EM2919.59	Vite	Screw	Vis	Schraube	Tornillo		1
12	EM2919.66	Vite	Screw	Vis	Schraube	Tornillo		3
13	EM1670.56	Grano	Dowel	Goujon	Stift	Clavija		2
14	EM1630.75	Gommino	Rubber pad	Pièce caoutchouc	Gummistück	Junta de goma		1
15	EM1630.79	Gommino	Rubber pad	Pièce caoutchouc	Gummistück	Junta de goma		1
16	EM2542.30	Rondella	Washer	Rondelle	Scheibe	Arandela		1
17	EM1630.81	Gommino	Rubber pad	Pièce caoutchouc	Gummistück	Junta de goma		1
18	EM1242.60	Volano	Flywheel	Volant	Schwungmasse	Volante		1
19	EM1630.58	Gommino	Rubber pad	Pièce caoutchouc	Gummistück	Junta de goma		1

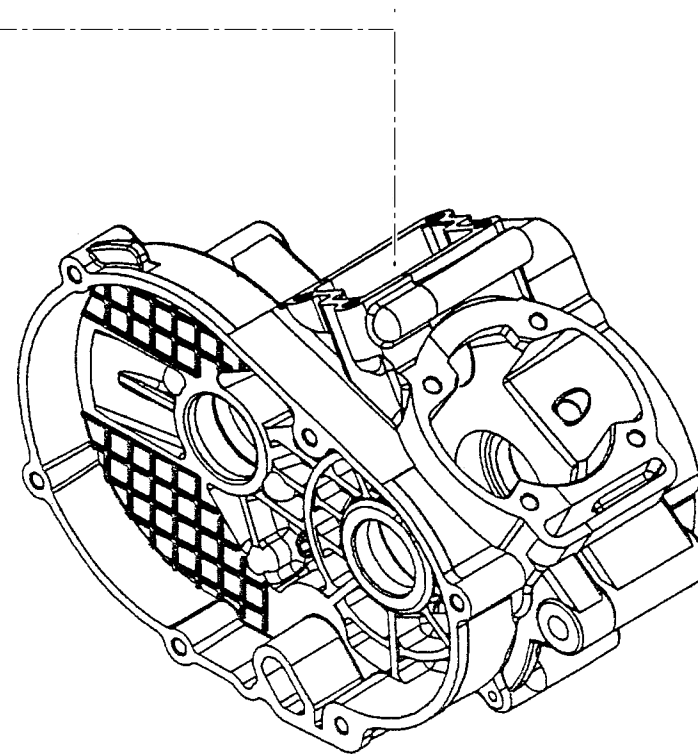
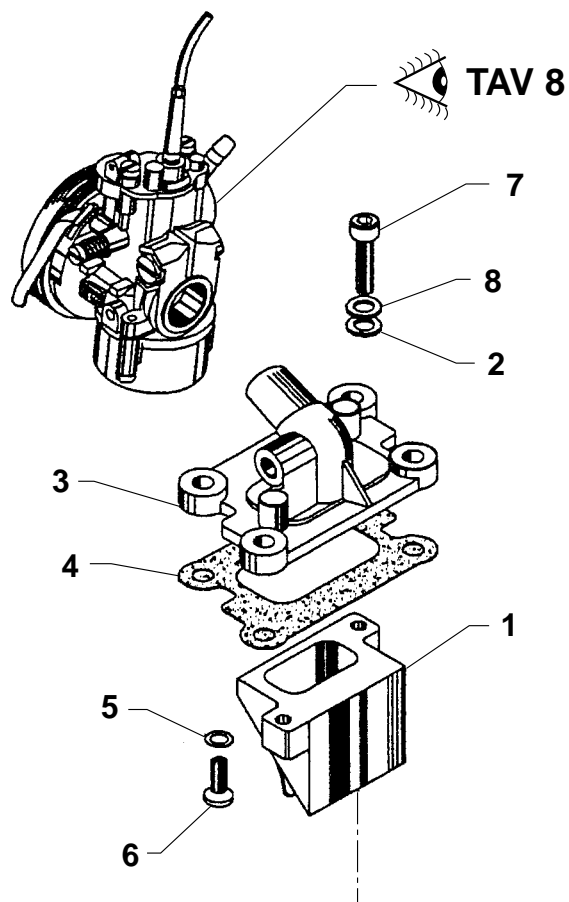

Pos. No. N. Index. Pos.	N.codice Code No. Nr. code Code Nr. N. cod.	Denominazione	Description	Désignation	Beschreibung	Descripción	Note Notes Notes Marke Notas	Q.tà Q.ty Q.te M.ge C.ad
1	EM2905.27	Valvola	Valve	Soupape	Ventil	Válvula		1
2	EM2540.01	Rondella	Washer	Rondelle	Scheibe	Arandela		4
3	EM2511.63	Racc. carburatore	Union	Raccord	Anschluss	Empalme carb.		1
4	EM1643.04	Guarnizione	Gasket	Garnitue	Dichtung	Junta		1
5	EM2540.86	Rondella	Washer	Rondelle	Scheibe	Arandela		2
6	EM2961.37	Vite	Screw	Vis	Schraube	Tornillo		2
7	EM2919.84	Vite	Screw	Vis	Schraube	Tornillo		4
8	EM2542.38	Rondella	Washer	Rondelle	Scheibe	Arandela		4

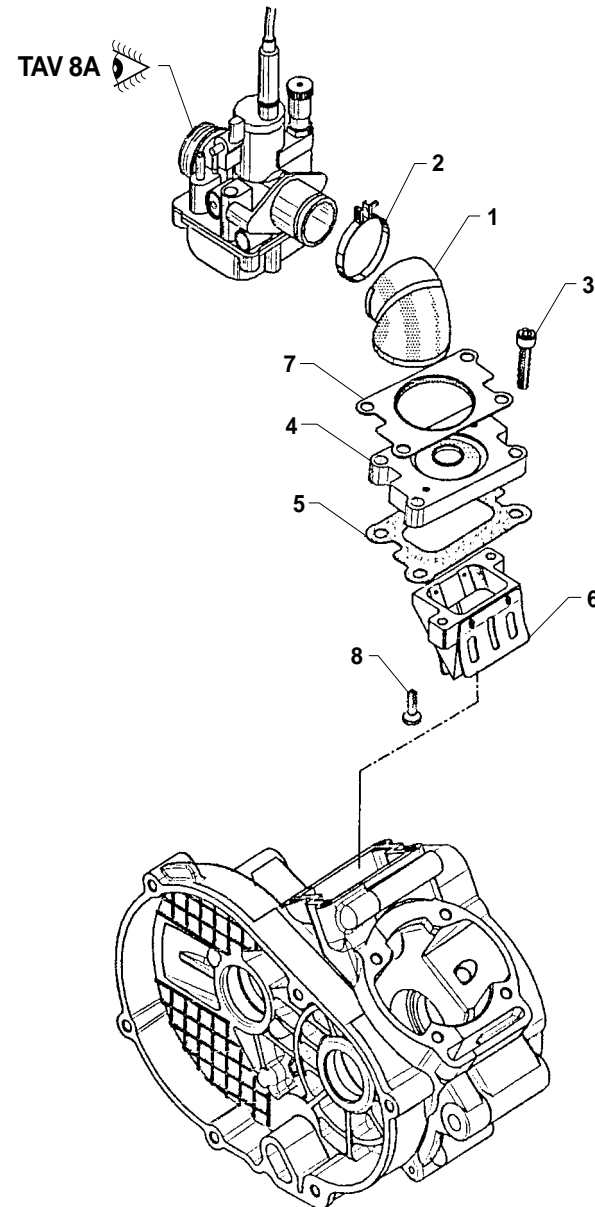

Pos. No. N. Index. Pos.	N.codice Code No. Nr. code Code Nr. N. cod.	Denominazione	Description	Désignation	Beschreibung	Descripción	Note Notes Notes Marke Notas	Q.tà Q.ty Q.te M.ge C.ad
1	EM2060.89	Manicotto	Sleeve	Manchon	Muffe	Manguito		1
2	EM1510.15	Fascetta	Clamp	Collier	Schelle	Banda		1
3	EM2919.86	Vite	Screw	Vis	Schraube	Tornillo		4
4	EM1180.27	Base raccordo carb.	Base	Socle	Lager	Base		1
5	EM1642.98	Guarnizione	Gasket	Garnitue	Dichtung	Junta		1
6	EM2905.41	Valvola	Valve	Soupape	Ventil	Válvula		1
7	EM2371.40	Piastrina	Plate	Plaquette	Plättchen	Placa		1
8	EM2960.51	Vite	Screw	Vis	Schraube	Tornillo		2

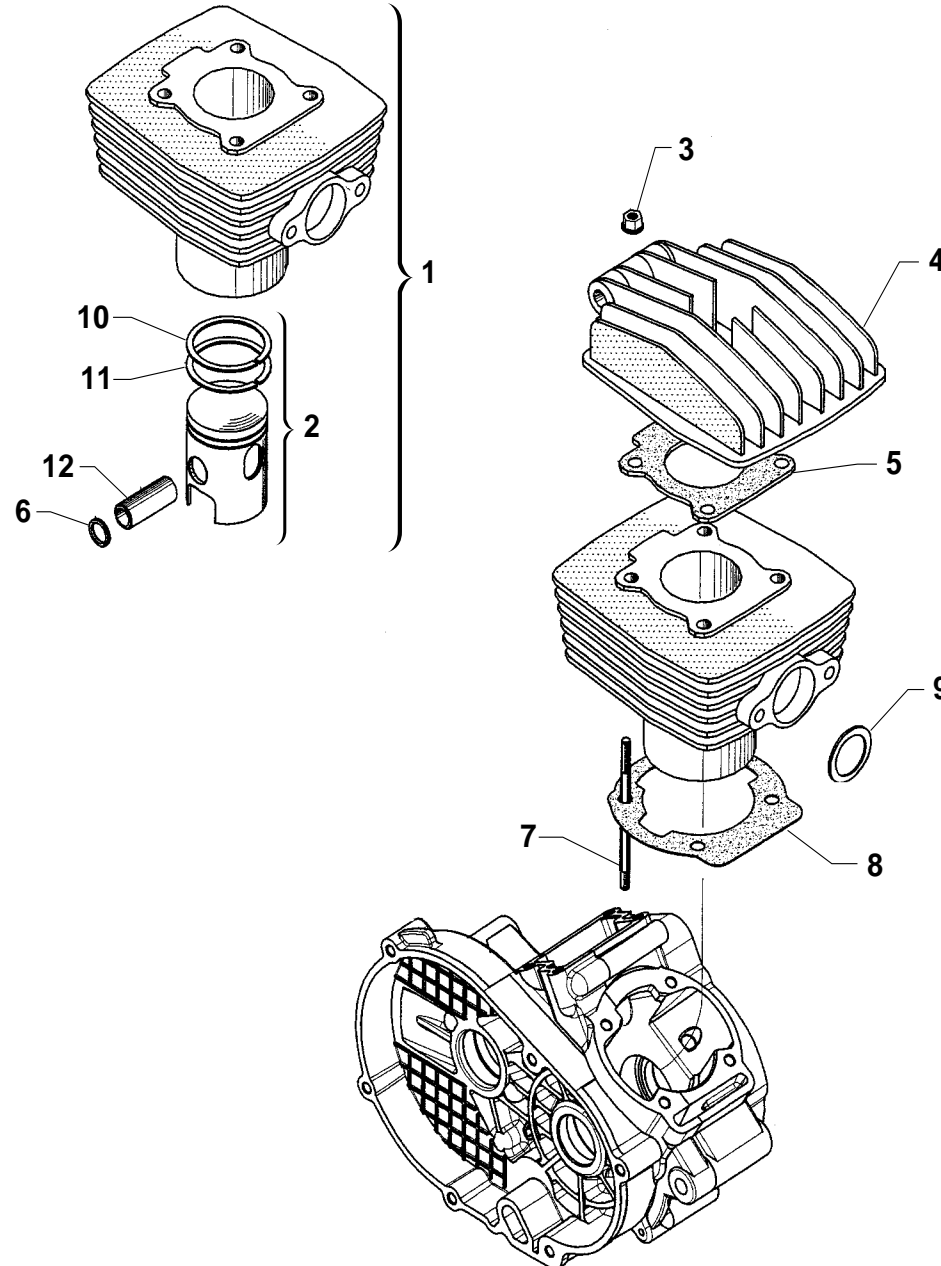

Pos. No. N. Index. Pos.	N.codice Code No. Nr. code Code Nr. N. cod.	Denominazione	Description	Désignation	Beschreibung	Descripción	Note Notes Notes Marke Notas	Q.tà Q.ty Q.te M.ge C.ad
1	EM7739.64	Cilindro + pistone	Cylinder + Piston	Cylindre + Piston	Zylinder + Kolben	Cilindro + Embolo		1
2	EM2301.86	Pistone	Piston	Piston	Kolbe	Pistón		1
3	EM1310.30	Dado	Nut	Ecrou	Mutter	Tuerca		4
4	EM2750.34	Testa	Cylinder head	Tetedu cylindre	Zylinderkopf	Cabeza		1
5	EM1641.21	Guarnizione	Gasket	Garnitue	Dichtung	Junta		1
6	EM1040.01	Anello	Ring	Bague	Ring	Anillo		2
7	EM2350.55	Prigioniero	Stud bolt	Prisonnier	Stiftschraube	Prisionero		4
8	EM1642.95	Guarnizione	Gasket	Garnitue	Dichtung	Junta		1
9	EM1643.08	Guarnizione	Gasket	Garnitue	Dichtung	Junta		1
10	EM2610.03	Segmento	Circlip	Segment	Kolbenring	Segmento		1
11	EM2610.44	Segmento	Circlip	Segment	Kolbenring	Segmento		1
12	EM2681.07	Spinotto	Gudgeon	Axe	Bolzen	Perno		1

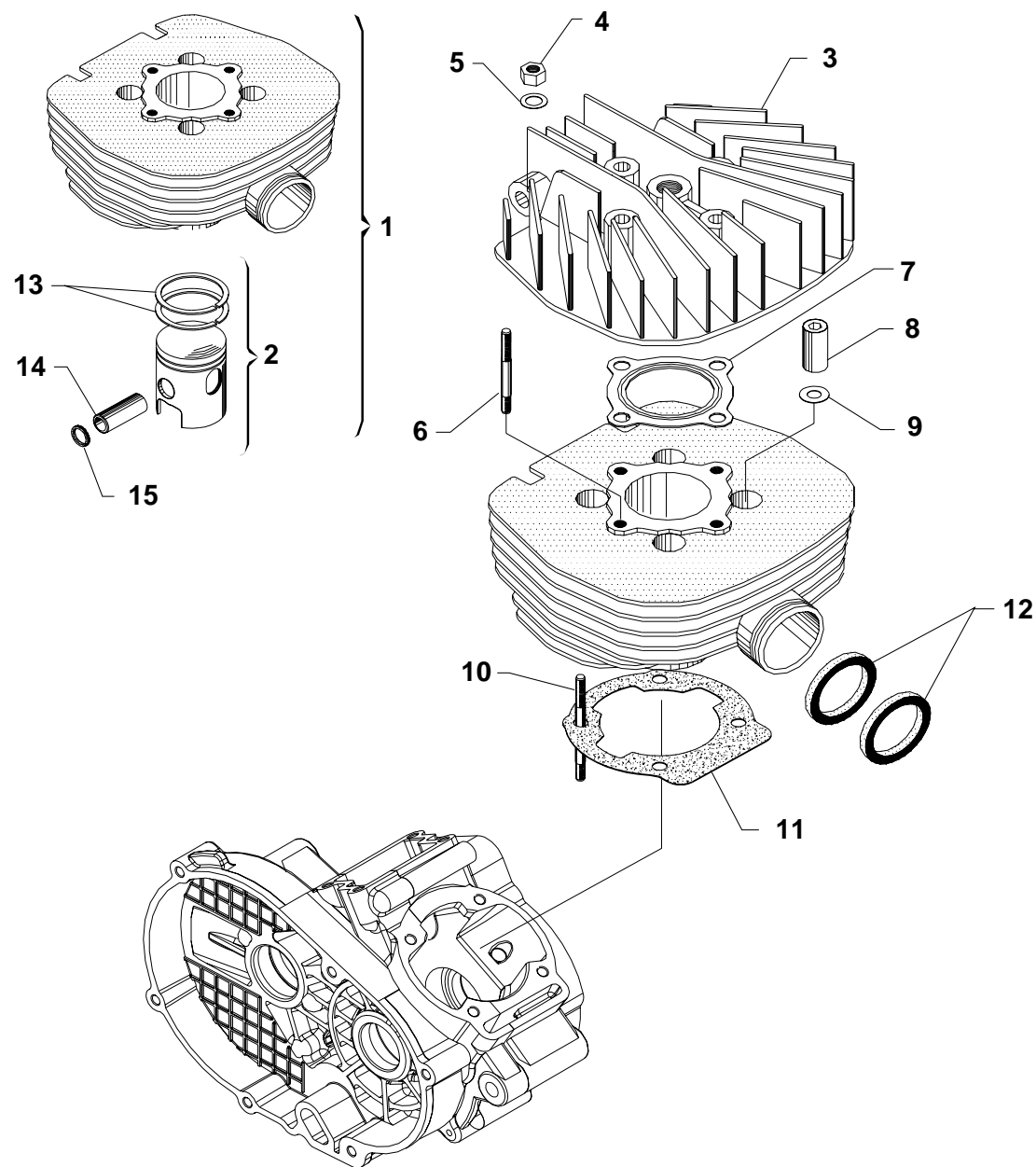

Pos. No. N. Index. Pos.	N.codice Code No. Nr. code Code Nr. N. cod.	Denominazione	Description	Désignation	Beschreibung	Descripción	Note Notes Notes Marke Notas	Q.tà Q.ty Q.te M.ge C.ad
1	EM7739.66	Cilindro + pistone	Cylinder + Piston	Cylindre + Piston	Zylinder + Kolben	Cilindro + Embolo		1
2	EM2301.82	Pistone	Piston	Piston	Kolbe	Pistón		1
3	EM2750.91	Testa	Cylinder head	Tetedu cylindre	Zylinderkopf	Cabeza		1
4	EM1310.05	Dado	Nut	Ecrou	Mutter	Tuerca		4
5	EM2540.81	Rondella	Washer	Rondelle	Scheibe	Arandela		4
6	EM2350.32	Prigioniero	Stud bolt	Prisonnier	Stiftschraube	Prisionero		4
7	EM1643.09	Guarnizione	Gasket	Garnitue	Dichtung	Junta		1
8	EM1273.36	Colonna	Stud bolt	Colonnette	Dorn	Esparrago		4
9	EM2540.01	Rondella	Washer	Rondelle	Scheibe	Arandela		8
10	EM2350.51	Prigioniero	Stud bolt	Prisonnier	Stiftschraube	Prisionero		4
11	EM1642.95	Guarnizione	Gasket	Garnitue	Dichtung	Junta		1
12	EM1070.65	Anello	Ring	Bague	Ring	Anillo		2
13	EM2610.56	Segmento	Circlip	Segment	Kolbenring	Segmento		2
14	EM2681.07	Spinotto	Gudgeon	Axe	Bolzen	Perno		1
15	EM1040.01	Anello	Ring	Bague	Ring	Anillo		2

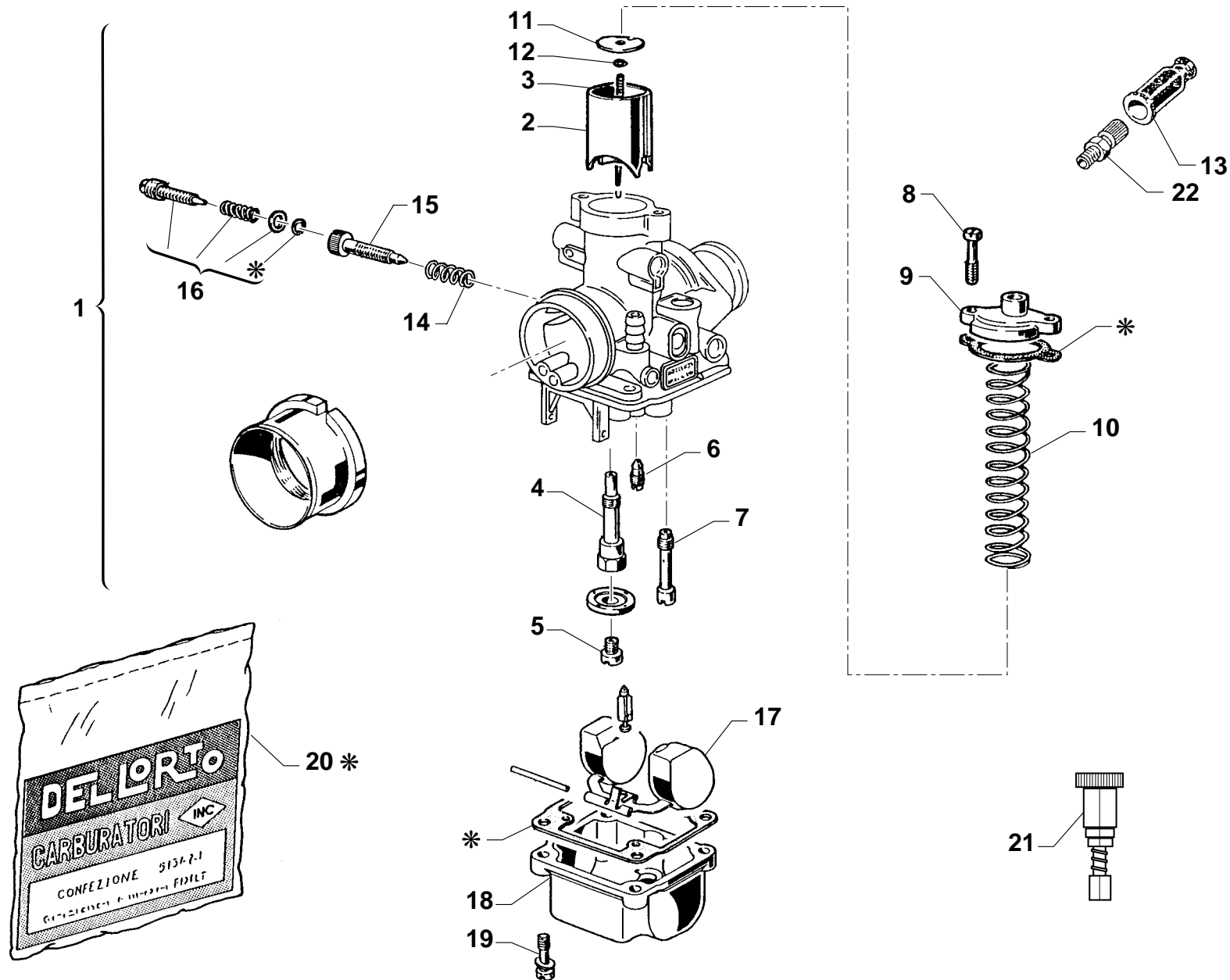

Pos. No. N. Index. Pos.	N.codice Code No. Nr. code Code Nr. N. cod.	Denominazione	Description	Désignation	Beschreibung	Descripción	Note Notes Notes Marke Notas	Q.tà Q.ty Q.te M.ge C.ad
1	XH329200	Carburatore	Carburetor	Carburateur	Vergaser	Carburador		1
2	ED15362.40.64	Valvola gas	Throttle valve	Papillon de gaz	Drosselklappe	Valvulá		1
3	ED16250.11.08	Spillo conico	Needle	Pointeau conique	Kon. Nadel	Pasador cónico		1
4	ED14671.212.28	Polverizzatore	Fuel nozzle	Pulvérisateur	Einspritzdüse	Pulverizador		1
5	ED06413.75.02	Getto massimo	Main jet	Gicleur principal	Hauptdüse	Chiclé máximo		1
6	ED11600.38.02	Getto minimo	Idle jet	Gicleur minimum	Leerlaufdüse	Chiclé mínimo		1
7	ED06217.50.02	Getto avviamento	Starting jet	Gicleur de starter	Starterdüse	Chiclé arranque		1
8	ED07526.00.36	Vite	Screw	Vis	Schraube	Tornillo		2
9	ED14166.00.53	Coperchio	Cover	Couvercle	Deckel	Tapa		1
10	ED15020.00.61	Piastrina	Plate	Plaque	Plättchen	Placa		1
11	ED13687.00.21	Fermo spillo conico	Needle valve stop	Arret pour épingles coniques	Kegelnadel-Sperrung	Tope espiga cónica		1
12	ED13681.00.21	Fermaglio	Retainer	Arret	Klammer	Abrazadera de sujeción		1
13	ED01476.00.06	Cappuccio	Cap	Capuchon	Kappe	Capuchón		1
14	ED01411.00.61	Molla	Spring	Ressort	Feder	Resorte		1
15	ED14056.00.37	Vite	Screw	Vis	Schraube	Tornillo		1
16	ED53086.00.78	Kit viti	Kit screw	Kit vis	Schraube	Kit tornillo		1
17	ED53053.00.78	Galleggiante	Float	Flotteur	Schwimmer	Flotador		1
18	ED13678.00.96	Vaschetta	Chamber	Cuvette	Becken	Cubeta		1
19	ED13709.00.36	Vite	Screw	Vis	Schraube	Tornillo		4
20	ED52620.00.77	Busta guarnizioni	Gasket set	Jeu joints	Dichtungssatz	Serie juntas		1
21	ED53012.00.78	Kit starter a leva	Kit for lever starter	Kit du starter à levier	Hebel-Starter-Satz	Kit starter de palanca		1
22	ED01104.00.37	Vite	Screw	Vis	Schraube	Tornillo		1

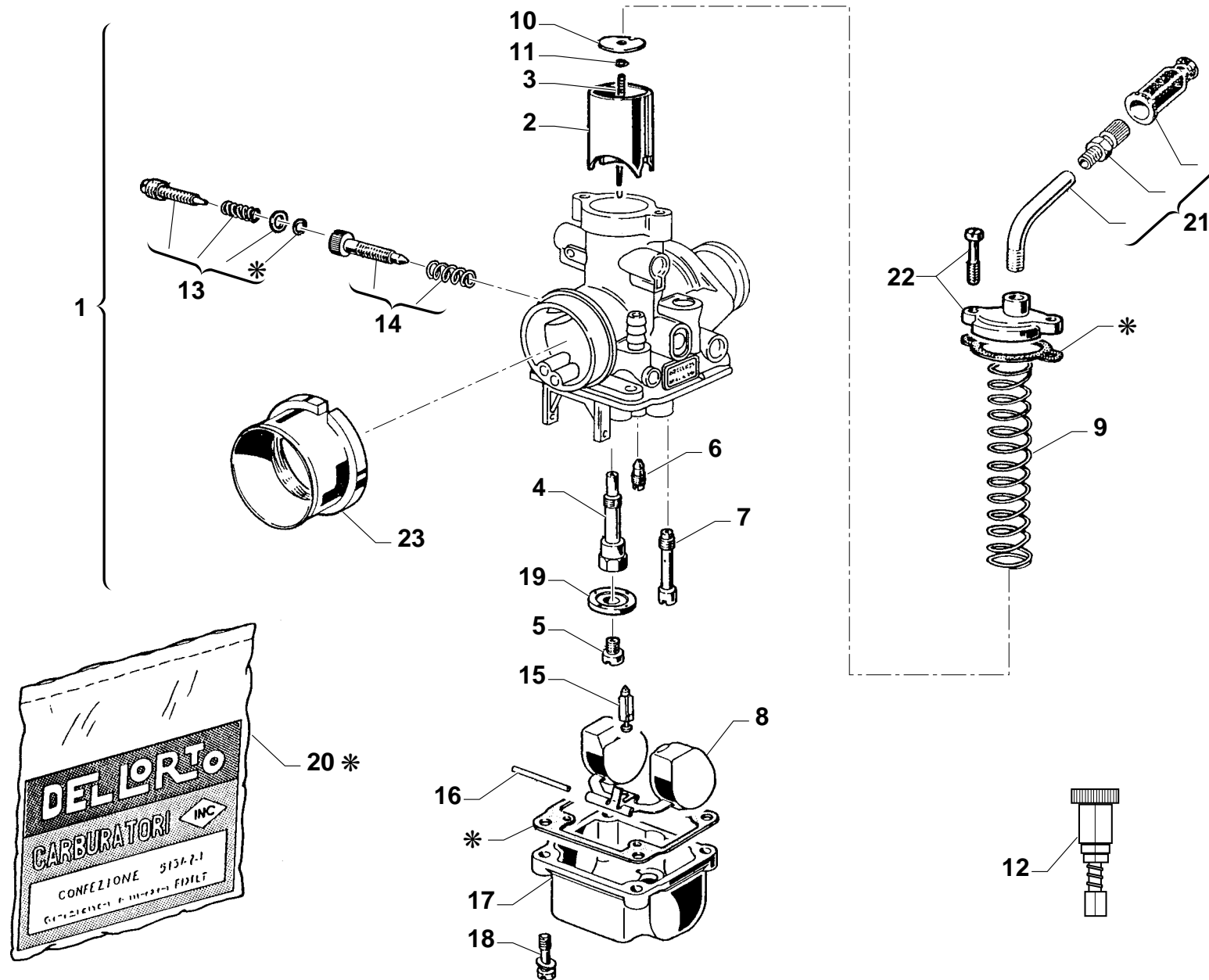

Pos. No. N. Index. Pos.	N.codice Code No. Nr. code Code Nr. N. cod.	Denominazione	Description	Désignation	Beschreibung	Descripción	Note Notes Notes Marke Notas	Q.tà Q.ty Q.te M.ge C.ad
1	XH246200	Assieme carburatore	Carburetor assy	Carburateur complet	Vegaser kpl.	Carburador compl.		1
2	ED09475.30.64	Valvola gas	Throttle valve	Papillon de gaz	Drosselklappe	Valvulá		1
3	ED09595.09.08	Spillo conico	Needle	Pointeau conique	Kon. Nadel	Pasador cónico		1
4	ED09654.262.28	Polverizzatore	Fuel nozzle	Pulvérisateur	Einspritzdüse	Pulverizador		1
5	ED01486.90.02	Getto massimo	Main jet	Gicleur principal	Hauptdüse	Chiclé máximo		1
6	ED01488.48.02	Getto minimo	Idle jet	Gicleur minimum	Leerlaufdüse	Chiclé mínimo		1
7	ED09501.60.02	Getto avviamento	Starting jet	Gicleur de starter	Starterdüse	Chiclé arranque		1
8	ED09450.01.80	Galleggiante	Float	Flotteur	Schwimmer	Flotador		1
9	ED09597.00.61	Molla	Spring	Ressort	Feder	Resorte		1
10	ED14958.00.21	Piastrina	Plate	Plaquette	Plättchen	Placa		1
11	ED09596.00.21	Fermo spillo conico	Needle valve stop	Arret pour épingles coniques	Kegelnadel-Sperrung	Tope espiga cónica		1
12	ED09538.00.64	Kit starter a leva	Kit for lever starter	Kit du starter à levier	Hebel-Starter-Satz	Kit starter de palanca		1
13	ED53024.00.78	Vite regolazione minimo	Screw	Vis	Schraube	Tornillo		1
14	ED53027.00.78	Vite regolazione gas	Screw	Vis	Schraube	Tornillo		1
15	ED02838.00.05	Spillo	Needle	Pinteau	Nadel	Pasador		1
16	ED09506.00.22	Perno	Pin	Pivot	Bolzen	Perno		1
17	ED09444.00.96	Vaschetta	Chamber	Cuvette	Becken	Cubeta		1
18	ED11836.00.36	Vite	Screw	Vis	Schraube	Tornillo		4
19	ED09779.00.52	Fondello	Bottom	Fond	Bodenscheibe	Casquillo		1
20	ED52526.00.77	Busta guarnizioni	Gasket set	Jeu joints	Dichtungssatz	Serie juntas		1
21	ED53027.00.78	Kit tubetto filo gas	Kit of pipe-cable-throttle	Kit du tuyau cable gaz	Gasdrahtrohr-Satz	Kit tubito cable gas		1
22	ED53036.00.78	Coperchio	Cover	Couvercle	Deckel	Tapa		1
23	ED04224.00.82	Raccordo	Union	Raccord	Anschluss	Empalme		1

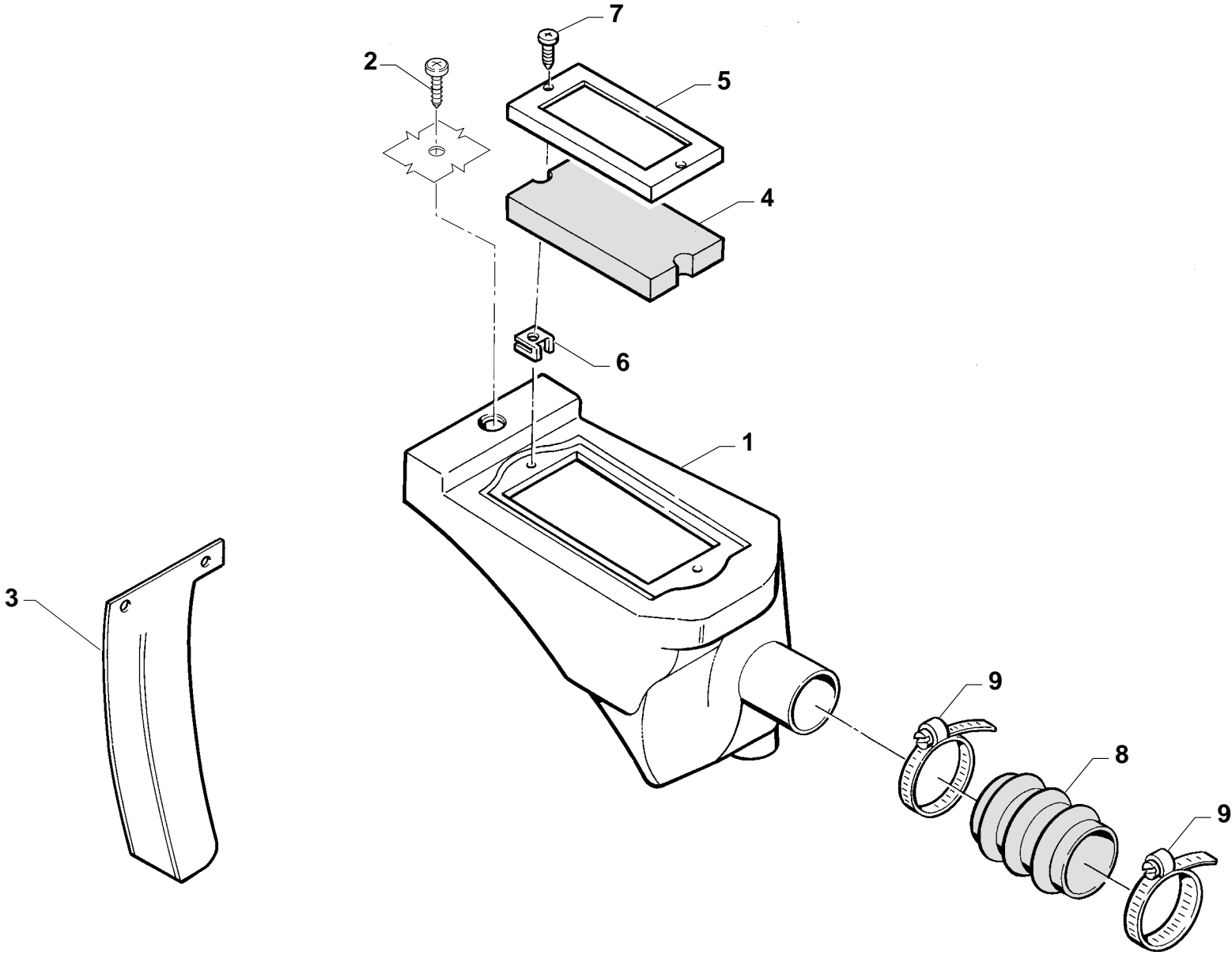

Pos. No. N. Index. Pos.	N.codice Code No. Nr. code Code Nr. N. cod.	Denominazione	Description	Désignation	Beschreibung	Descripción	Note Notes Notes Marke Notas	Q.tà Q.ty Q.te M.ge C.ad
1	XH236800	Scatola filtro	Air filter box	Boîte filtre	Filterkasten	Caja filtro aire		1
2	N1000710	Vite	Screw	Vis	Schraube	Tornillo		1
3	XH324800	Protezione	Guard	Protection	Schutz	Protección		1
4	XH236900	Filtro	Filter	Filtre	Filter	Filtro		1
5	XH233300	Telaietto	Frame	Cadre	Cadre	Bastidor pequeño		1
6	N6002803	Dado	Nut	Ecrou	Mutter	Tuerca		2
7	N1000406	Vite	Screw	Vis	Schraube	Tornillo		2
8	EA6911	Manicotto	Sleeve	Manchon	Muffe	Manguito		1
9	N1010401	Fascetta	Clamp	Collier	Schelle	Banda		2

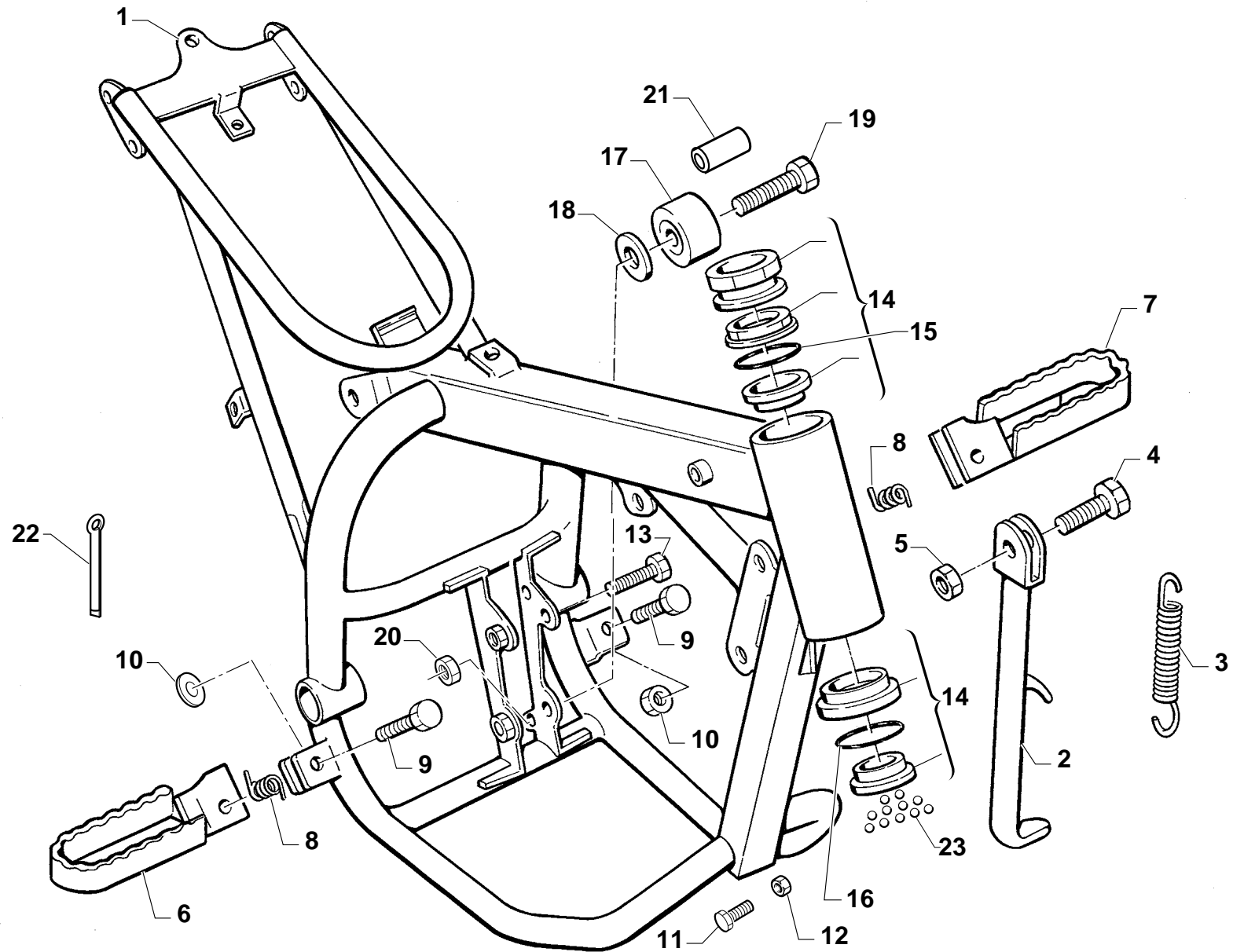

Pos. No. N. Index. Pos.	N.codice Code No. Nr. code Code Nr. N. cod.	Denominazione	Description	Désignation	Beschreibung	Descripción	Note Notes Notes Marke Notas	Q.tà Q.ty Q.te M.ge C.ad
1	XH3023A0	Telaio	Frame	Chassis	Rahmen	Bastidor		1
2	XH2371A5	Gamba lat.	Side stand	Bequille lat.	Seitenstander	Horquilla lateral		1
3	XH235000	Molla	Spring	Ressort	Feder	Resorte		1
4	N1000323	Vite	Screw	Vis	Schraube	Tornillo		1
5	N1002501	Dado	Nut	Ecrou	Mutter	Tuerca		1
6	EH8AA072564	Ass. poggiapiedi dx.	R. foot rest	Repose pied D.	R. Fussraste	Prisioneros der.		1
7	EH80A072564	Ass. poggiapiedi sx.	L. foot rest	Repose pied G.	L. Fussraste	Prisioneros izq.		1
8	EH800073341	Molla	Spring	Ressort	Feder	Resorte		2
9	EH800073140	Perno	Pin	Pivot	Bolzen	Perno		2
10	N1001522	Rosetta	Washer	Rondelle	Scheibe	Arandela		2
11	N1000335	Vite	Screw	Vis	Schraube	Tornillo		1
12	XH238917	Dado	Nut	Ecrou	Mutter	Tuerca		1
13	N1000305	Vite	Screw	Vis	Schraube	Tornillo		2
14	XH235800	Serie sterzo	Steering assy	Groupe direction	Reihe Lenker	Juego direccion	511	1
14	XH237300	Serie sterzo	Steering assy	Groupe direction	Reihe Lenker	Juego direccion	510	1
15	N0012001	Anello	Ring	Bague	Ring	Anillo		1
16	N0012002	Anello	Ring	Bague	Ring	Anillo	510	1
16	N0012007	Anello	Ring	Bague	Ring	Anillo	511	1
17	XH302600	Rullo catena	Chain roller	Aiguille	Rolle	Rodilo cadena		2
18	N1001503	Rosetta	Washer	Rondelle	Scheibe	Arandela		2
19	N1000305	Vite	Screw	Vis	Schraube	Tornillo		2
20	N1003003	Dado	Nut	Ecrou	Mutter	Tuerca		2
21	XH207911	Distanziale	Spacer	Entretoise	Distanzstück	Separador		2
22	N1012803	Copiglia	Split pin	Goupille	Splint	Clavija		2
23	N0016003	Sfera	Ball	Bille	Kugel	Esfera	511	26

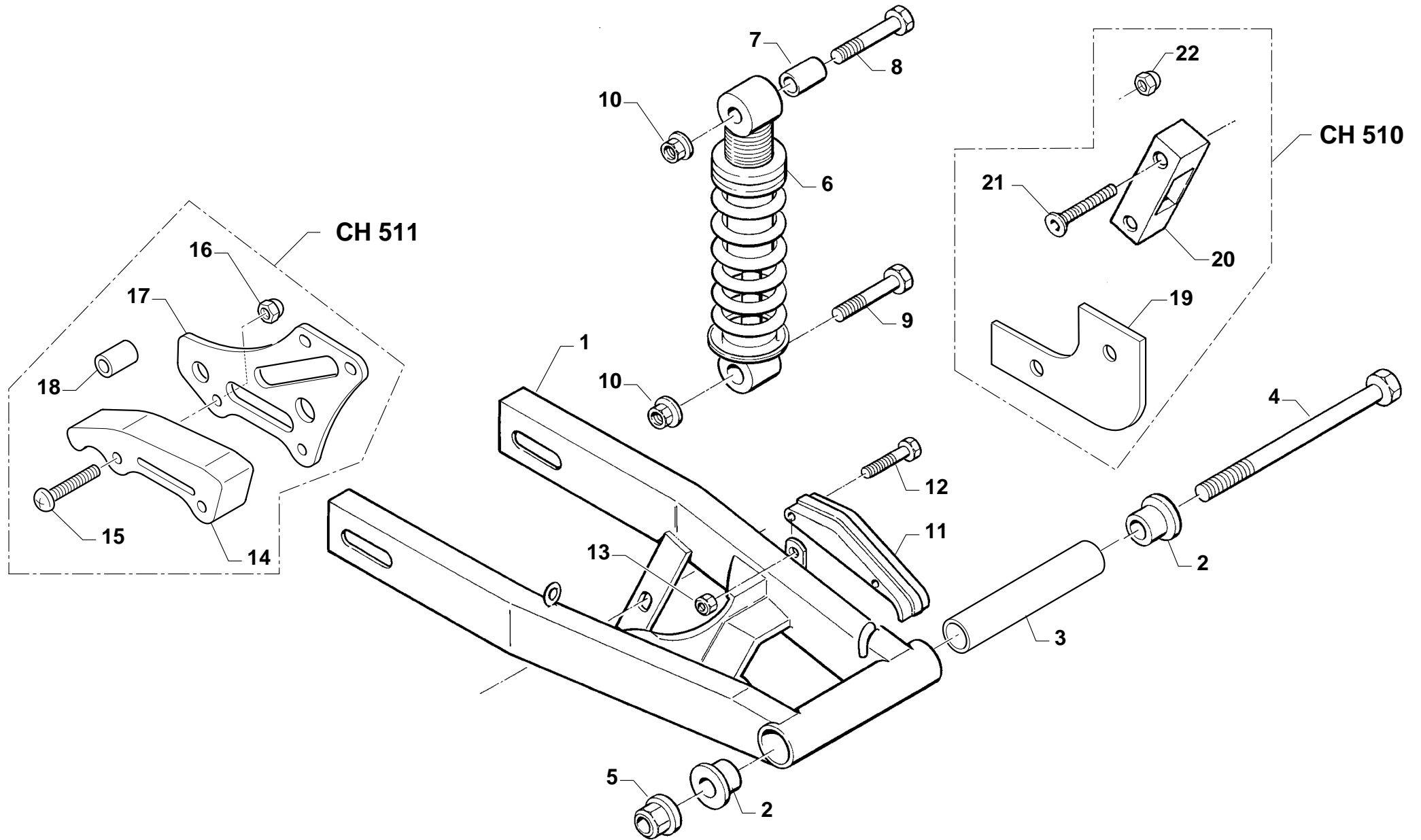

Pos. No. N. Index. Pos.	N.codice Code No. Nr. code Code Nr. N. cod.	Denominazione	Description	Désignation	Beschreibung	Descripción	Note Notes Notes Marke Notas	Q.tà Q.ty Q.te M.ge C.ad
1	XH3058A0	Forcellone	Fork	Fourche	Gabel	Horquilla		1
2	XH232401	Boccola	Bush	Douille	Buchse	Casquillo		2
3	XH326400	Distanziale	Spacer	Entretoise	Distanzstück	Separador		1
4	N1000345	Vite	Screw	Vis	Schraube	Tornillo		1
5	N1002504	Dado	Nut	Ecrou	Mutter	Tuerca		1
6	XH304101	Ammortizzatore	Shock-absorber	Ammortisseur	Stossdämpfer	Amortiguador	511	1
6	XH329000	Ammortizzatore	Shock-absorber	Ammortisseur	Stossdämpfer	Amortiguador	510	1
7	XH238918	Distanziale	Spacer	Entretoise	Distanzstück	Separador		1
8	N1000308	Vite	Screw	Vis	Schraube	Tornillo		1
9	N1000317	Vite	Screw	Vis	Schraube	Tornillo		1
10	N1003002	Dado	Nut	Ecrou	Mutter	Tuerca		2
11	XH235601	Pattino catena	Chain slider	Glissière	Gleitbahn	Plato cadena		1
12	N1000322	Vite	Screw	Vis	Schraube	Tornillo		1
13	N1002505	Dado	Nut	Ecrou	Mutter	Tuerca		1
14	XH313400	Gomma	Rubber pad	Pièce caoutchouc	Gummistück	Goma	511	1
15	N1000905	Vite	Screw	Vis	Schraube	Tornillo	511	4
16	N1003001	Dado	Nut	Ecrou	Mutter	Tuerca	511	4
17	XH312600	Piastra	Plate	Plaque	Platte	Placa	511	2
18	XH207912	Distanziale	Spacer	Entretoise	Distanzstück	Separador	511	2
19	XH329300	Piastra	Plate	Plaque	Platte	Placa	510	1
20	XH220500	Guidacatena	Chain guide	Guide-chaîne	Kettenführung	Guía-cadena	510	1
21	N1000101	Vite	Screw	Vis	Schraube	Tornillo	510	2
22	N1002502	Dado	Nut	Ecrou	Mutter	Tuerca	510	2

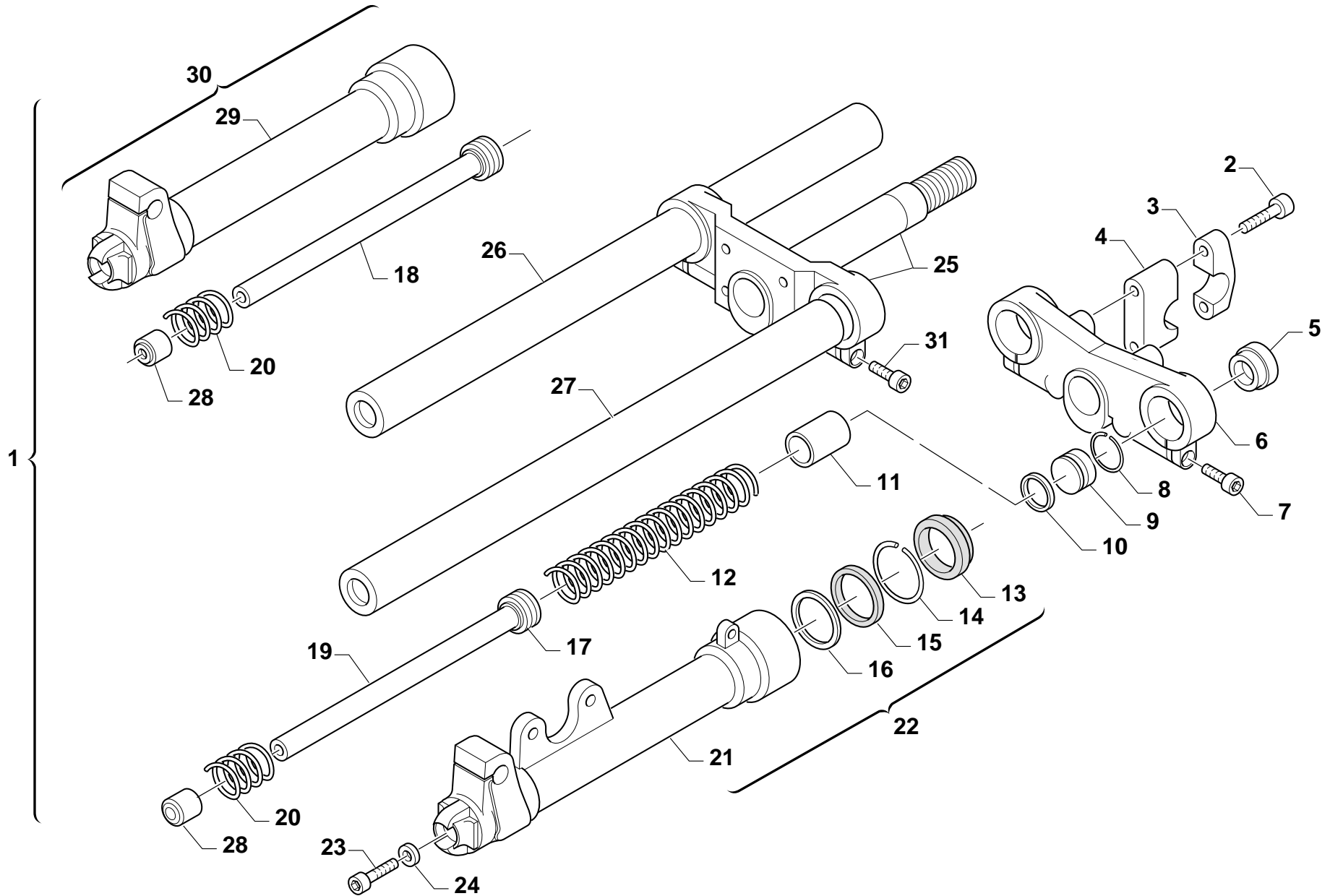

Pos. No. N. Index. Pos.	N.codice Code No. Nr. code Code Nr. N. cod.	Denominazione	Description	Désignation	Beschreibung	Descripción	Note Notes Notes Marke Notas	Q.tà Q.ty Q.te M.ge C.ad
1	XH320400	Ass. sospensione ant.	Front-weel susp.	Suspension av.	Vorderachsaufängung	Suspensió del.		1
2	ER520043AR	Vite	Screw	Vis	Schraube	Tornillo		4
3	ER505034A	Morsetto manubrio	Clamp	Etau	Klemme	Abrazadera		2
4	ER505033A	Base	Base	Socle	Basis-	Base		2
5	ER532774	Tappo	Plug	Bouchon	Verschluss	Tapón		2
6	ER501443A	Testa di sterzo	Steering head	Tête direction	Lenkkopf	Cabezal de dirección		1
7	ER520001AR	Vite	Screw	Vis	Schraube	Tornillo		2
8	ER523277	Anello elastico	Split ring	Anneau ressort	Sprengring	Anillo elástico		2
9	ER504148B	Tappo stelo	Plug	Bouchon	Verschluss	Tapón		2
10	ER528084	Anello OR	O-Ring	Bague OR	O-Ring	Anillo OR		2
11	ER5181215	Tubetto	Pipe	Tuyau	Rohr	Tube		2
12	ER5141214	Molla	Spring	Ressort	Feder	Resorte		2
13	ER533297	Raschiapolvere	Dust scraper	Racloir poudre	Pulverabschaber	Rascador de polvo		2
14	ER523264	Anello elastico	Split ring	Anneau ressort	Sprengring	Anillo elástico		2
15	ER528230A	Anello di tenuta	Seal ring	Bague d'étanchéité	Dichtungsring	Anillo de retención		2
16	ER522226AA	Rondella	Washer	Rondelle	Scheibe	Arandela		2
17	ER524157	Segmento	Circlip	Segment	Kolbenring	Segmento		1
18	ER803932	Pompante DX	R.H. pumping element	Element de pompage D.	Pumpenelement,R.	Bombeadora compl.derch.		1
19	ER803934	Pompante SX	L.H pumping element	Element de pompage G.	Pumpenelement,L.	Bombeadora completa izq.		1
20	ER5141015	Contromolla	Return spring	Ressort de rappel	Gegenfeder	Resorte antagonista		2
21	ER5031656A	Gamba Sx	L.H. stem	Tige gauche	Linker Schaft	Vaeilla izq.		1
22	ER5031656A/R	Gamba sx compl.	L.H fork leg assy	Fourche compl.G.	Telegabel,Kpl.L	Horquill,izq.compl.		1
23	ER520001AR	Vite	Screw	Vis	Schraube	Tornillo		2
24	ER522225	Rondella	Washer	Rondelle	Scheibe	Arandela		2
25	ER7051087A	Base di sterzo con perno	Steering crown with pin	Socle de direction avec pivot	Gabelbrücke mit Bolzen	Base de dirección con perno		1
26	ER708230R	Tubo portante	Pipe	Tuyau	Rohr	Tube		1
27	ER708231R	Tubo portante	Pipe	Tuyau	Rohr	Tube		1
28	ER512068	Tampone	Pad	Tampon	Stopfen	Tampón		2
29	ER5031595A	Gamba dx	R.H. stem	Tige droite	Rechter Schaft	Vaeilla der.		1
30	ER5031595A/R	Gamba Dx compl.	R.H fork leg assy	Fourche complete D.	Telegabel Kpl.R.	Horquilla derech.compl.		1
31	ER520048AR	Vite	Screw	Vis	Schraube	Tornillo		4

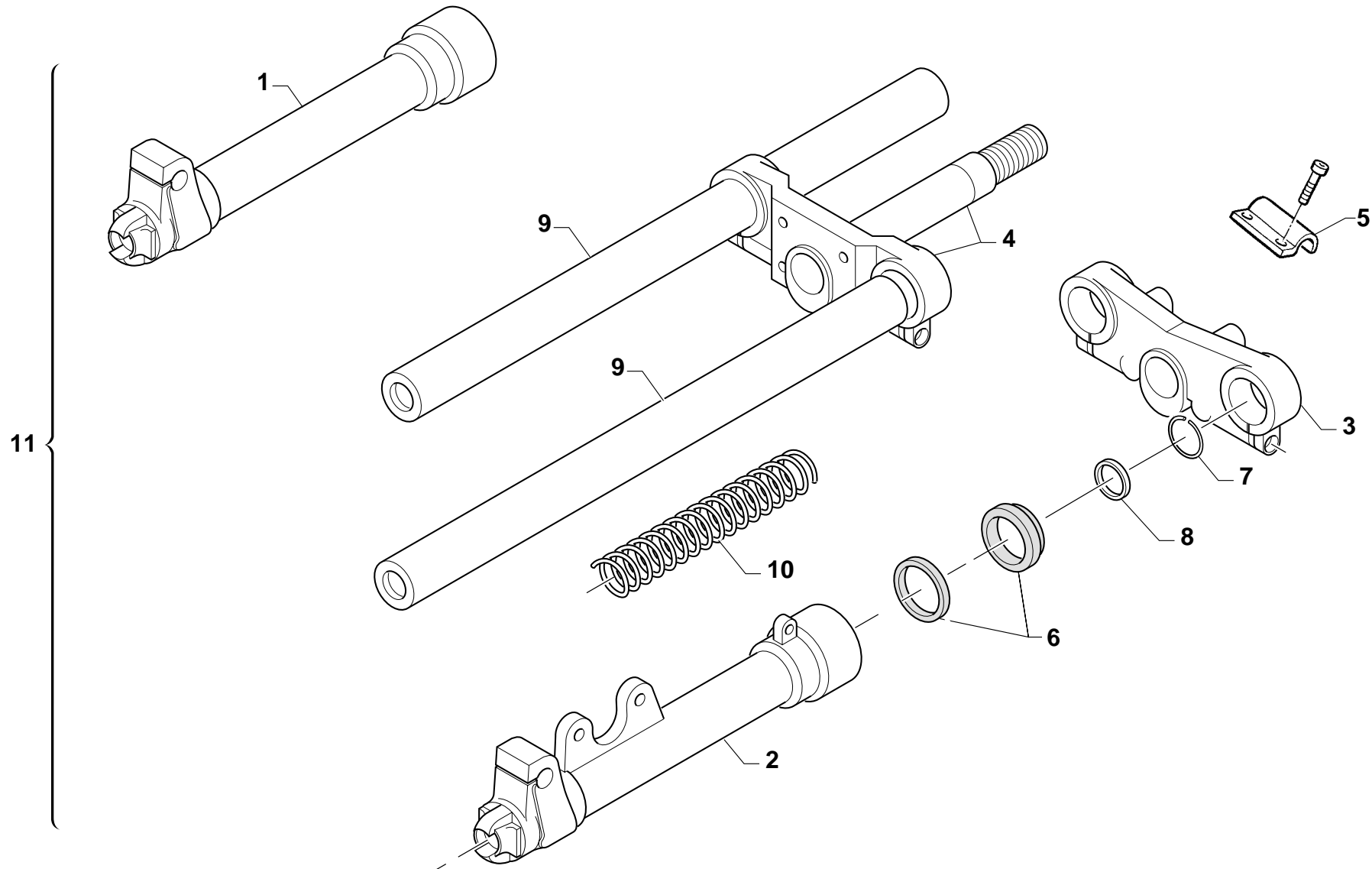

Pos. No. N. Index. Pos.	N.codice Code No. Nr. code Code Nr. N. cod.	Denominazione	Description	Désignation	Beschreibung	Descripción	Note Notes Notes Marke Notas	Q.tà Q.ty Q.te M.ge C.ad
1	EP800131	Pompante DX	R.H. pumping element	Element de pompage D.	Pumpenelement, R.	Bombeadora compl. derch.		1
2	EP800130	Pompante SX	L.H. pumping element	Element de pompage D.	Pumpenelement, L.	Bombeadora completa izqrda.		1
3	EP150520	Testa	Cylinder head	Tetedu cylindre	Zylinderkopf	Cabeza		1
4	EP150521	Base	Base	Socle	Lager	Base		1
5	EP180160	Morsetto	Clamp	Etau	Klemme	Abrazadera		1
6	EP650580	Busta guarnizioni	Gasket set	Jeu joints	Dichtungssatz	Serie juntas		1
7	EP125109	Anello	Ring	Bague	Ring	Anillo		1
8	EP600645	Gommino	Rubber pad	Pièce caoutchouc	Gummistück	Junta de goma		2
9	EP300866	Stelo	Rod	Tige	Kolbenstange	Varilla		2
10	EP100075	Molla	Spring	Ressort	Feder	Resorte		1
11	XH275100	Ass. sospensione ant.	Front-weel susp.	Suspension av.	Vorderachsaufängung	Suspensión del.		1

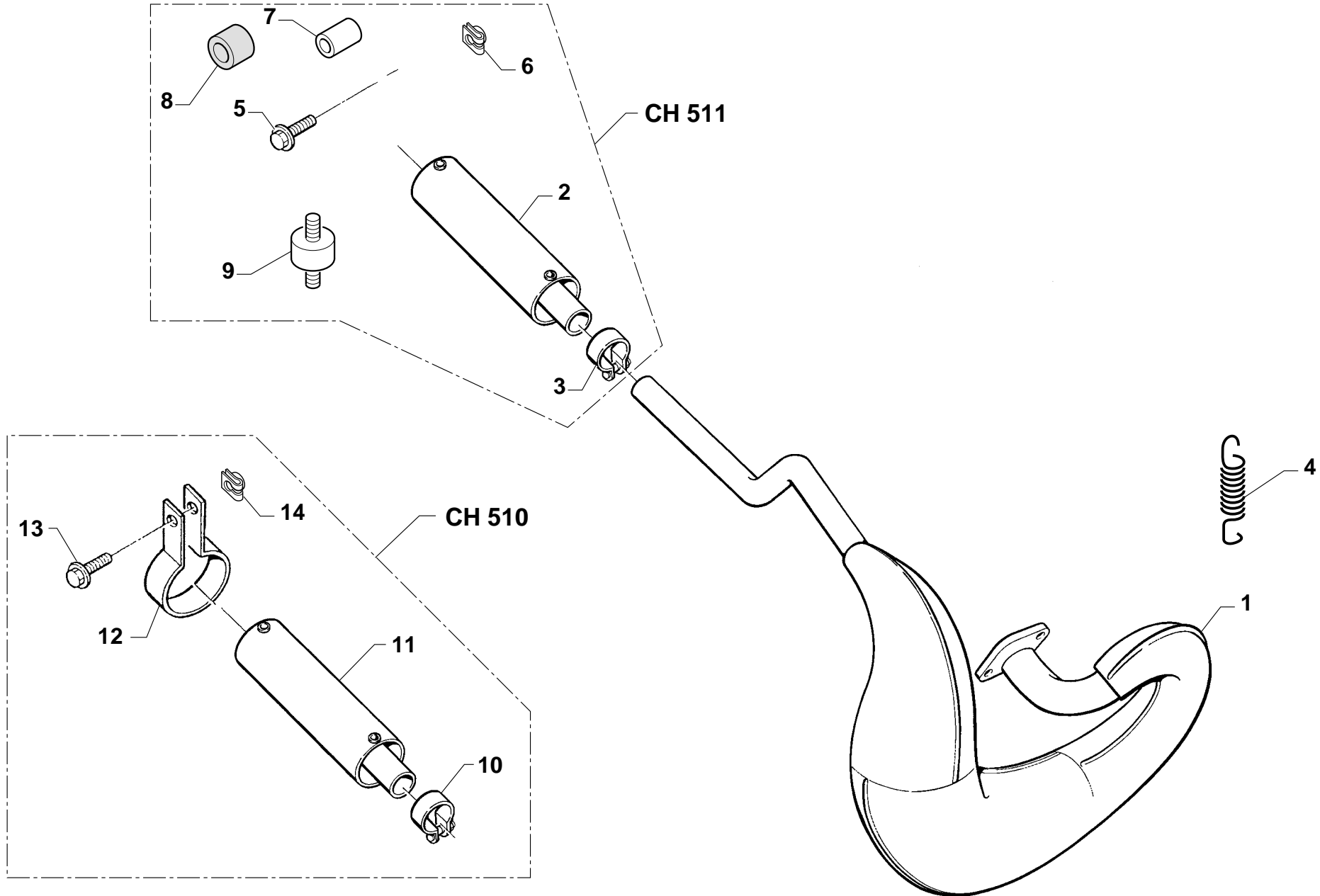

Pos. No. N. Index. Pos.	N.codice Code No. Nr. code Code Nr. N. cod.	Denominazione	Description	Désignation	Beschreibung	Descripción	Note Notes Notes Marke Notas	Q.tà Q.ty Q.te M.ge C.ad
1	XH3325A0	Tubo di scarico	Exhaust pipe	Tuyauterie	Leitung	Tuberia	511	1
1	XH3331A0	Tubo di scarico	Exhaust pipe	Tuyauterie	Leitung	Tuberia	510	1
2	XH304500	Silenziatore di scarico	Exhaust silencer	Silencieux d'échappement	Schalldämpfer	Silenciador de escape	511	1
3	EA6975	Gommino	Rubber pad	Pièce caoutchouc	Gummistück	Junta de goma	511	1
4	XH301600	Molla	Spring	Ressort	Feder	Resorte	511	2
5	N1000107	Vite	Screw	Vis	Schraube	Tornillo	511	1
6	N6002802	Dado a graffetta	Nut	Ecrou	Mutter	Tuerca	511	1
7	XH236709	Distanziale	Spacer	Entretoise	Distanzstück	Separador	511	2
8	N0011302	Gommino	Rubber pad	Pièce caoutchouc	Gummistück	Junta de goma	511	2
9	N0017602	Antivibrante	Silent-block	Antivibration	Schwingungsdämpfer	Anti-vibrador	511	2
10	N2010201	Fascetta	Clamp	Collier	Schelle	Banda	510	1
11	XH275200	Silenziatore	silencer	Silencieux	Schalldämpfer	Silenciador	510	1
12	N2010301	Fascetta	Clamp	Collier	Schelle	Banda	510	1
13	N1000303	Vite	Screw	Vis	Schraube	Tornillo	510	1
14	N6002802	Dado	Nut	Ecrou	Mutter	Tuerca	510	1

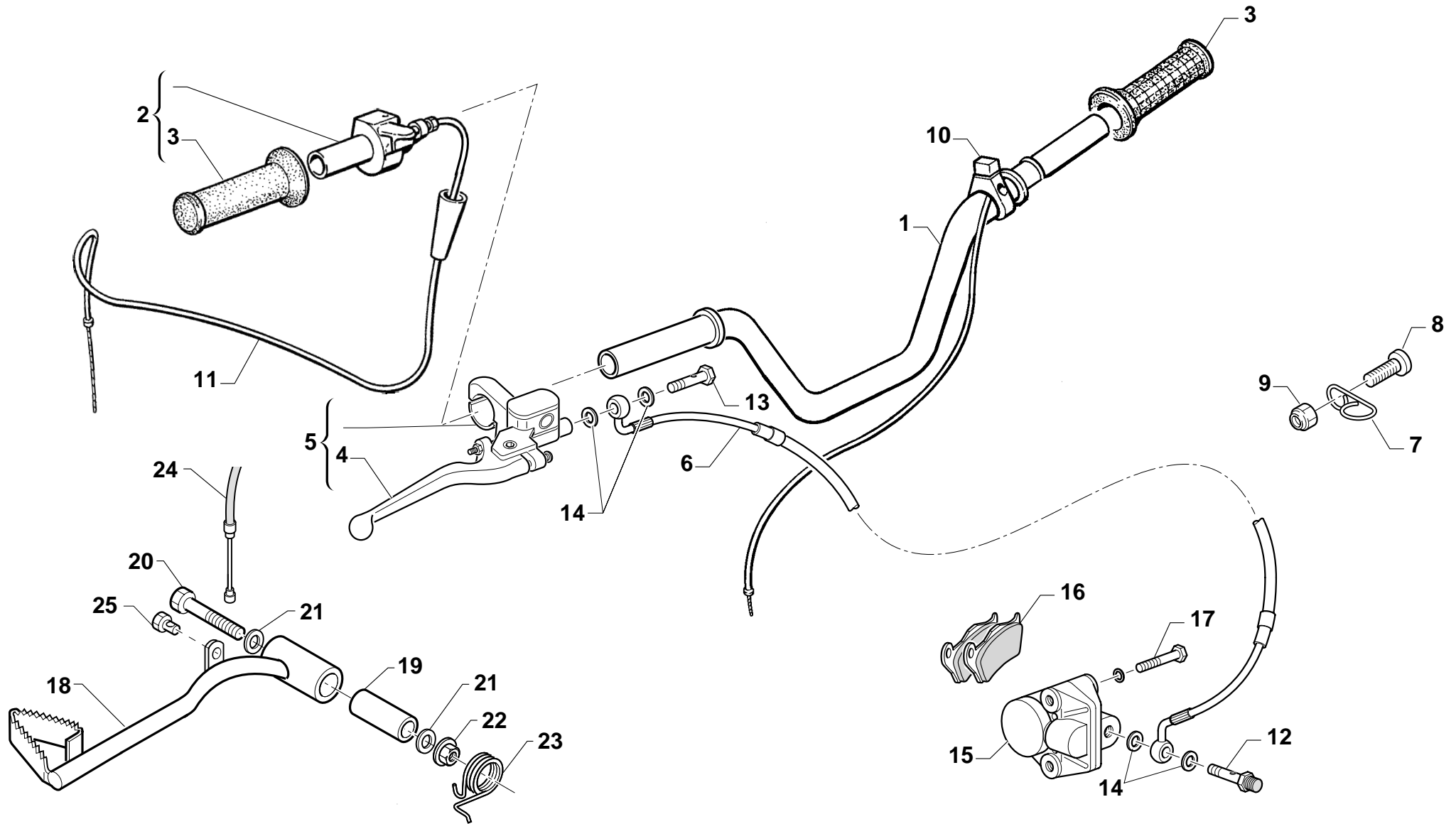

Pos. No. N. Index. Pos.	N.codice Code No. Nr. code Code Nr. N. cod.	Denominazione	Description	Désignation	Beschreibung	Descripción	Note Notes Notes Marke Notas	Q.tà Q.ty Q.te M.ge C.ad
1	XH2841A0	Manubrio	Hanblebar	Guidon	Lenker	Manillar		1
2	XH218500	Comando gas con manopole	Throttle control	Comm.gaz	Gasgriff	Mando gas		1
3	XH244900	Coppia manopole	Grip pair	Couple poignées	Griffpaar	Pareja manoplas		1
4	EJ134.75.900C	Leva freno anteriore	Front brake lever	Levier frein avant	Vorderer Bremshebel	Palanca freno delantero		1
5	EJ116.00.820C	Comando freno anteriore	Front brake control	Commande frein av.	Bremshebel Vorderradbr.	Mando freno ant.		1
6	XH324200	Tubo freno anteriore	Trasmiss.front brake	Trasmission frein av.	Bremsseil Vorderradbr	Trasmis.fr.del.		1
7	XH245601	Anello	Ring	Bague	Ring	Anillo		1
8	N1000902	Vite	Screw	Vis	Schraube	Tornillo		1
9	N1002505	Dado	Nut	Ecrou	Mutter	Tuerca		1
10	XH244800	Pulsante di massa	Mass push button	Bouton de masse	Masseschalter	Pulsador de tierra		1
11	XH224001	Trasmissione comando gas	Gas control trasmiss	Trasmiss.comm.gaz	Gaszug	Trasmis.m.gas		1
12	EJ190.00.001C	Vite raccordo con sfiato	Screw	Vis	Schraube	Tornillo		1
13	EJ190.99.060	Vite raccordo tubo olio	Screw	Vis	Schraube	Tornillo		1
14	EJ190.99.095	Rosetta	Washer	Rondelle	Scheibe	Arandela		4
15	XH323.000	Pinza freno	Brake caliper	Etrier frein	Bremssattel	Pinza		1
16	EJ290.99.087	Pastiglie	Pads	Plaquettes	Bremsbelafpaar	Pastillas		2
17	N1000714	Vite	Screw	Vis	Schraube	Tornillo		2
18	XH3046A0	Pedale freno post.	Rear brake pedal	Frein arrière á pedal	Hintere pedalbremse	Kit pedal freno trsero		1
19	XH244400	Bussola	Bushing	Douille	Buchse	Manguito		1
20	N1000319	Vite	Screw	Vis	Schraube	Tornillo		1
21	N1001503	Rosetta	Washer	Rondelle	Scheibe	Arandela		2
22	N1002501	Dado	Nut	Ecrou	Mutter	Tuerca		1
23	XH305500	Molla	Spring	Ressort	Feder	Resorte		1
24	XH225204	Trasmissione freno post.	Rear brake trasmission	Commande frein arrière	Hinterbremsegetriebe	Trans. freno trasero		1
25	N0011003	Nottolino	Pawl	Cliquet	Klinke	Pestillo		1

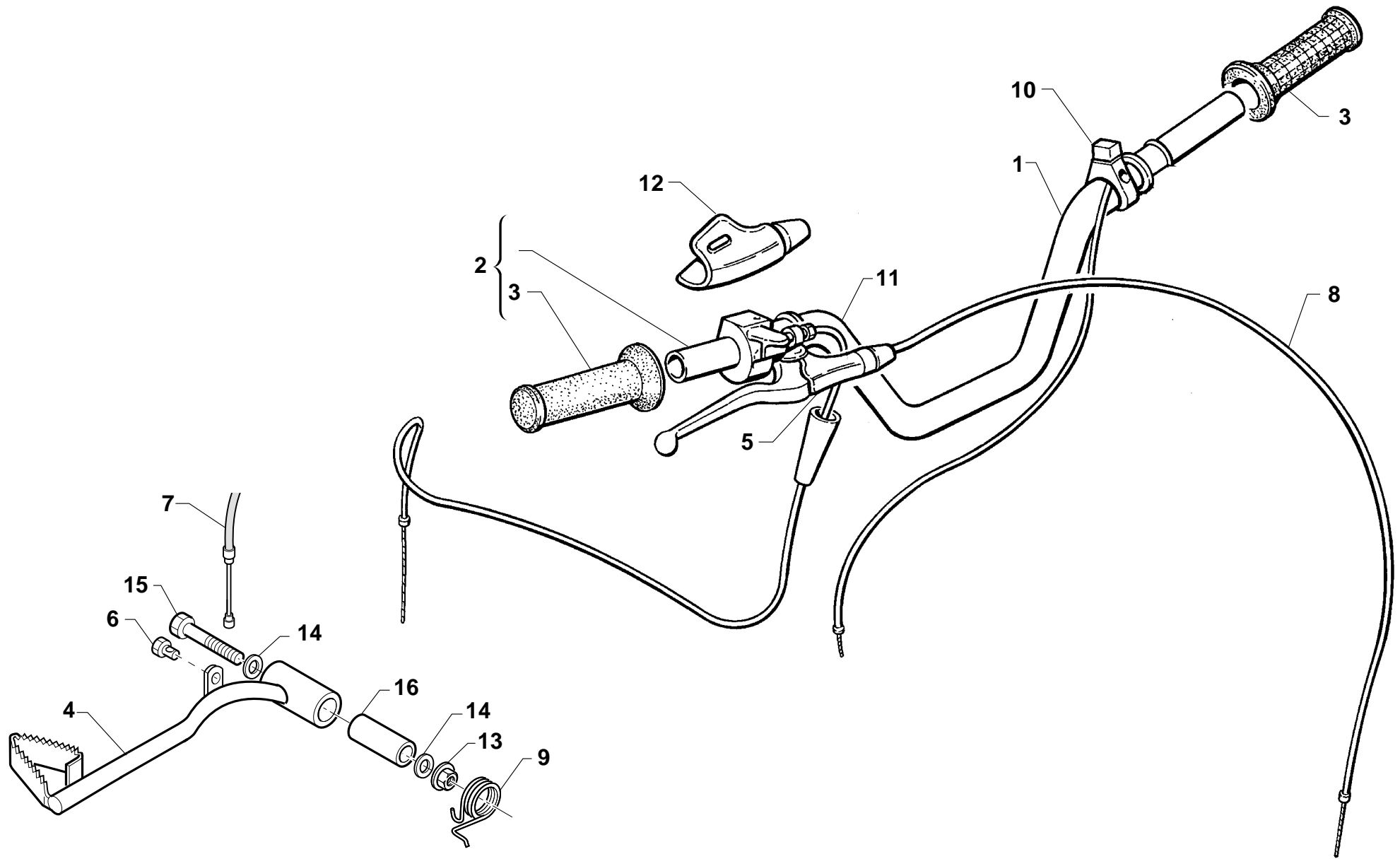

Pos. No. N. Index. Pos.	N.codice Code No. Nr. code Code Nr. N. cod.	Denominazione	Description	Désignation	Beschreibung	Descripción	Note Notes Notes Marke Notas	Q.tà Q.ty Q.te M.ge C.ad
1	XH2841A0	Manubrio	Hanblebar	Guidon	Lenker	Manillar		1
2	XH218500	Comando gas con manopole	Throttle control	Comm.gaz	Gasgriff	Mando gas		1
3	XH244900	Coppia manopole	Grip pair	Couple poignées	Griffpaar	Pareja manoplas		1
4	XH3046A0	Pedale freno post.	Rear brake pedal	Pedale frein arrier	Hinter bremsegetriebe	Pedal trasero		1
5	EN1364.04.00	Comando freno anteriore	Front brake control	Commande frein av.	Bremshebel Vorderradbr.	Mando freno ant.		1
6	N0011003	Nottolino	Pawl	Cliquet	Klinke	Pestillo		1
7	XH225204	Trasmissione freno post.	Rear brake trasm	Commande frein arrier	Hinter bremsegetriebe	Comando freno trasero		1
8	XH284600	Trasmissione freno ant.	Front brake trasm.	Commande frein av.	Vorder bremsegetriebe	Comando freno ant.		1
9	XH305500	Molla	Spring	Ressort	Feder	Resorte		1
10	XH244800	Pulsante	Push	Pulsant	Druckknopf	Pulsador		1
11	XH224001	Trasmissione comando gas	Gas control trasmiss	Trasmiss. comm. gaz	Gaszug	Transmis.m. gas		1
12	XH237000	Coprileva	Lever cover	Caches p. levier	Hebelschüteter	Cubre palanca		1
13	N1002501	Dado	Nut	Ecrou	Mutter	Tuerca		1
14	N1001503	Rosetta	Washer	Rondelle	Scheibe	Arandela		2
15	N1000319	Vite	Screw	Vis	Schraube	Tornillo		1
16	XH244400	Bussola	Bushing	Douille	Buchse	Manguito		1

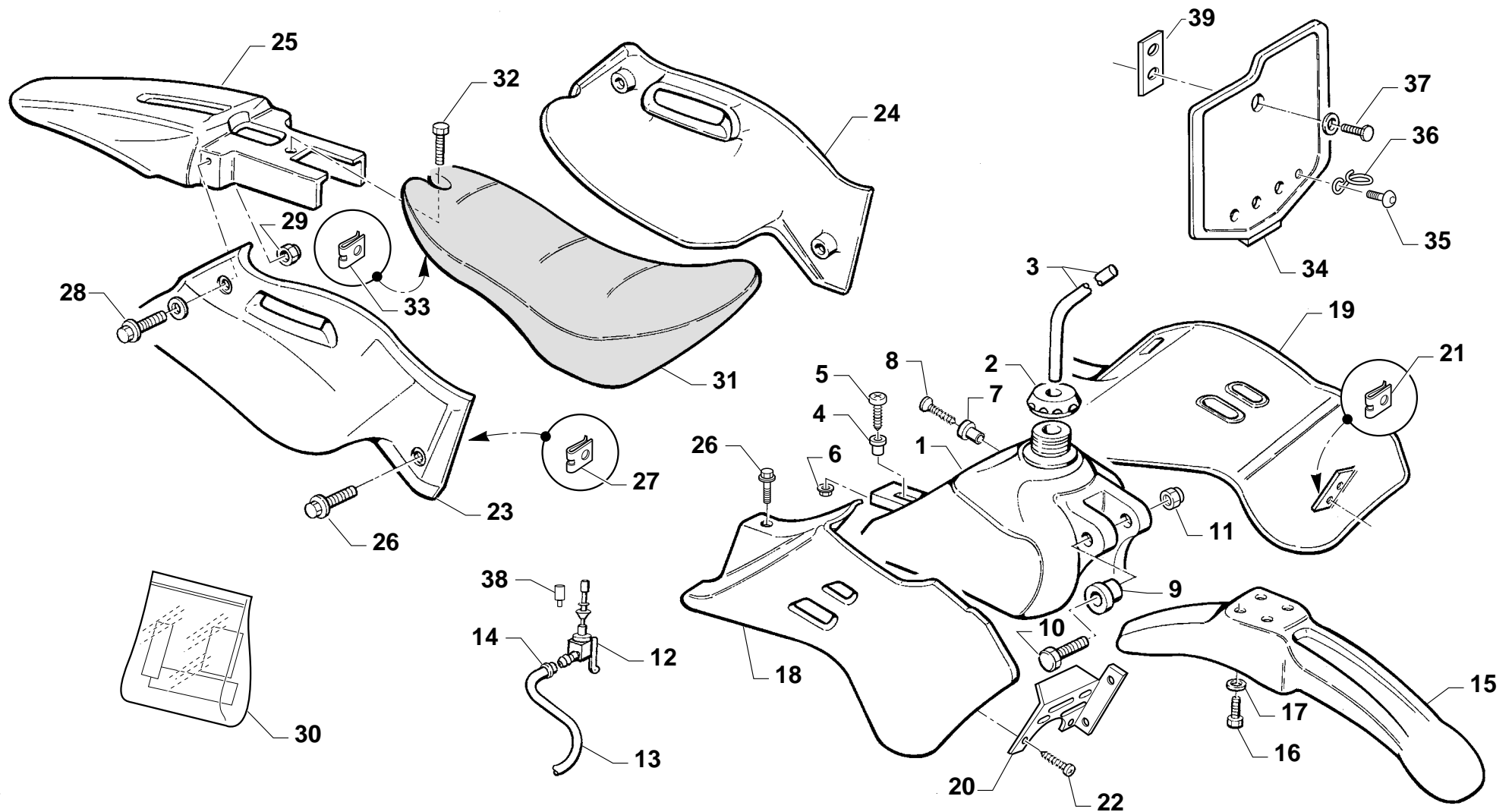

Pos. No. N. Index. Pos.	N.codice Code No. Nr. code Code Nr. N. cod.	Denominazione	Description	Désignation	Beschreibung	Descripción	Note Notes Notes Marke Notas	Q.tà Q.ty Q.te M.ge C.ad
1	XH222400	Serbatoio	Fuel tank	Réservoir	Kraftstoffbehälter	Dep.carburante		1
2	XH222500	Tappo	Plug	Bouchon	Verschluss	Tapón		1
3	N0011501	Tubo di sfiato	Pipe	Tuyau	Rohr	Tubo		1
4	XH236701	Bussola	Bushing	Douille	Buchse	Manguito		1
5	N1000302	Vite	Screw	Vis	Schraube	Tornillo		1
6	N6002802	Dado a graffetta	Nut	Ecrou	Mutter	Tuerca		1
7	XH223900	Distanziale	Spacer	Entretoise	Distanzstück	Separador		1
8	N1000103	Vite	Screw	Vis	Schraube	Tornillo		1
9	XH236700	Bussola	Bushing	Douille	Buchse	Manguito		2
10	N1000204	Vite	Screw	Vis	Schraube	Tornillo		1
11	N1003001	Dado	Nut	Ecrou	Mutter	Tuerca		1
12	XH222800	Rubinetto benzina	Fuel cock	Robinet de combustible	Kraftstoffhahn	Llave de paso gasolina		1
13	N0011505	Tubo benzina	Pipe	Tuyau	Rohr	Tubo		1
14	N3010001	Fascetta	Clamp	Collier	Schelle	Banda		2
15	XH2494A0	Parafango anteriore	Front mudguard	Garde-boue avant	Vord. Kotfluegel	Guarda-barros delantero		1
16	N1000710	Vite	Screw	Vis	Schraube	Tornillo		4
17	N1001502	Rosetta	Washer	Rondelle	Scheibe	Arandela		4
18	XH2882A0	Pannello anteriore DX	Rh.front panel	Panneau av.droite	Vordere rechte Verkleid	Panel del.der.		1
19	XH2883A0	Pannello anteriore SX	L.H front panel	Panneau av.gauche	Vordere linke Verkleid	Panel del. izq.		1
20	XH275400	Griglia DX	R.H grille	Grille D.	Gitter R.	Parilla der.		1
21	N6002801	Dado a graffetta	Nut	Ecrou	Mutter	Tuerca		2
22	N1000401	Vite	Screw	Vis	Schraube	Tornillo		4
23	XH2430A0	Fianchetto posteriore DX	Rear right valance panel	Capot ar.d.	Hint.rechtes seintenteil	Costado post.dx		1
24	XH2429A0	Fianchetto posteriore SX	Rear left valance panel	Capot ar.g.	Hint.links Seintenteil	Costado post.sx		1
25	XH2215C0	Parafango posteriore	Rear mudguard	Garde-boue ar.	Hinterradkotflügel	Guardabarros tras.		1
26	N1000710	Vite	Screw	Vis	Schraube	Tornillo		2
27	N6002802	Dado a graffetta	Nut	Ecrou	Mutter	Tuerca		2
28	N1000714	Vite	Screw	Vis	Schraube	Tornillo		2
29	N1002502	Dado	Nut	Ecrou	Mutter	Tuerca		2
30	XH328500	Kit decalco	Transfer kit	Kit autocollant	Satz Abziehbilder	Kit decalco	510	1
30	XH331100	Kit decalco	Transfer kit	Kit autocollant	Satz Abziehbilder	Kit decalco	511	1
31	XH2437B0	Sella	Saddle	Selle	Sitzbank	Silli		1
32	N1000709	Vite	Screw	Vis	Schraube	Tornillo		1
33	N6002802	Dado a graffetta	Nut	Ecrou	Mutter	Tuerca		1
34	XH2209B0	Portanumero	Number holder	Supp.numéro	Nummernhalter	Portanúmero		1
35	N1000710	Vite	Screw	Vis	Schraube	Tornillo		1
36	XH245600	Anello	Ring	Bague	Ring	Anillo		1
37	N1000901	Vite	Screw	Vis	Schraube	Tornillo		1
38	XH275600	Prolunga	Fuel lock insert	Prolonge	Verlaengerung	Extensión		1
39	XH209402	Piastrina	Plate	Plaquette	Plättchen	Placa		1

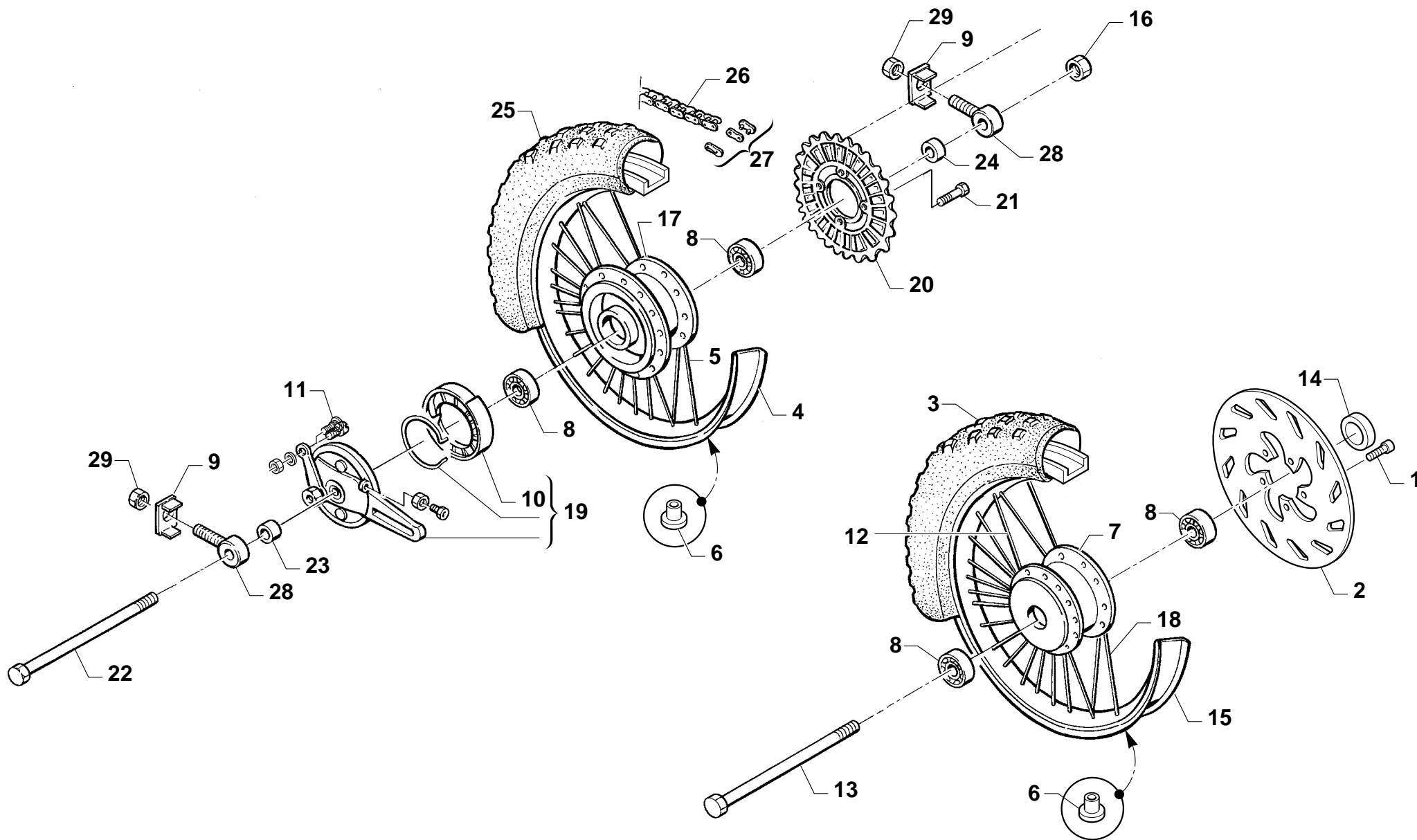

Pos. No. N. Index. Pos.	N.codice Code No. Nr. code Code Nr. N. cod.	Denominazione	Description	Désignation	Beschreibung	Descripción	Note Notes Notes Marke Notas	Q.tà Q.ty Q.te M.ge C.ad
1	N1000207	Vite	Screw	Vis	Schraube	Tornillo		5
2	XH323300	Disco freno anteriore	Brake disc	Disque frein	Bremsscheibe	Disco freno		1
3	N0005511	Pneumatico	Tyre	Pneu	Reifen	Neumático		1
4	N3004602	Cerchio	Rim	Jante	Felge	Llanta		1
5	N2007908	Raggio	Spoke	Bras	Speiche	Radio		36
6	N2007502	Nipplo	Nipple	Nipple	Nippel	Nipple		72
7	XH287600	Mozzo	Hub	Moyeau	Radnabe	Cubo		1
8	N0003502	Cuscinetto	Bearing	Roulement	Lager	Cojinete		4
9	N1000347	Vite	Screw	Vis	Schraube	Tornillo		2
10	XH295500	Assieme ceppi con molle	Complete blake bloks	Sabots de frein complets	Komplete bremsbacke	Mordaza compl.		1
11	EIMT.03570501	Vite	Screw	Vis	Schraube	Tornillo		1
12	N2007912	Raggio DX	R.H. spoke	Bras D	Speiche R	Radio DER		18
13	XH286700	Perno ruota anteriore	Pin	Pivot	Bolzen	Perno rueda		1
14	XH238915	Distanziale	Spacer	Entretoise	Distanzstück	Separador		1
15	N3005002	Cerchio	Rim	Jante	Felge	Llanta		1
16	N1002602	Dado	Nut	Ecrou	Mutter	Tuerca		1
17	XH318900	Mozzo	Hub	Moyeau	Radnabe	Cubo		1
18	N2007911	Raggio	Spoke	Bras	Speiche	Radio		18
19	XH295600	Coperchio portaceppi	Cover	Couvercle	Deckel	Tapa		1
20	XH288707	Corona	Ring gear	Couronne	Kranz	Corona		1
21	EICO.03350600	Vite	Screw	Vis	Schraube	Tornillo		5
22	XH239005	Perno	Pin	Pivot	Bolzen	Perno		1
23	XH238920	Distanziale	Spacer	Entretoise	Distanzstück	Separador		1
24	XH238921	Distanziale	Spacer	Entretoise	Distanzstück	Separador		1
25	N0005503	Pneumatico post.	Reae tyre	Pneu	Reifen	Neumático		1
26	N0009005	Catena	Chain	Chaîne	Kette	Cadena		1
27	N0009102	Giunto	Coupling	Joint	Kupplung	Junta		1
28	XH302401	Tendicatena	Chain adjuster	Tendeur de chaine	Kettenspanner	Tensor de cadena		2
29	N1002603	Dado	Nut	Ecrou	Mutter	Tuerca		2

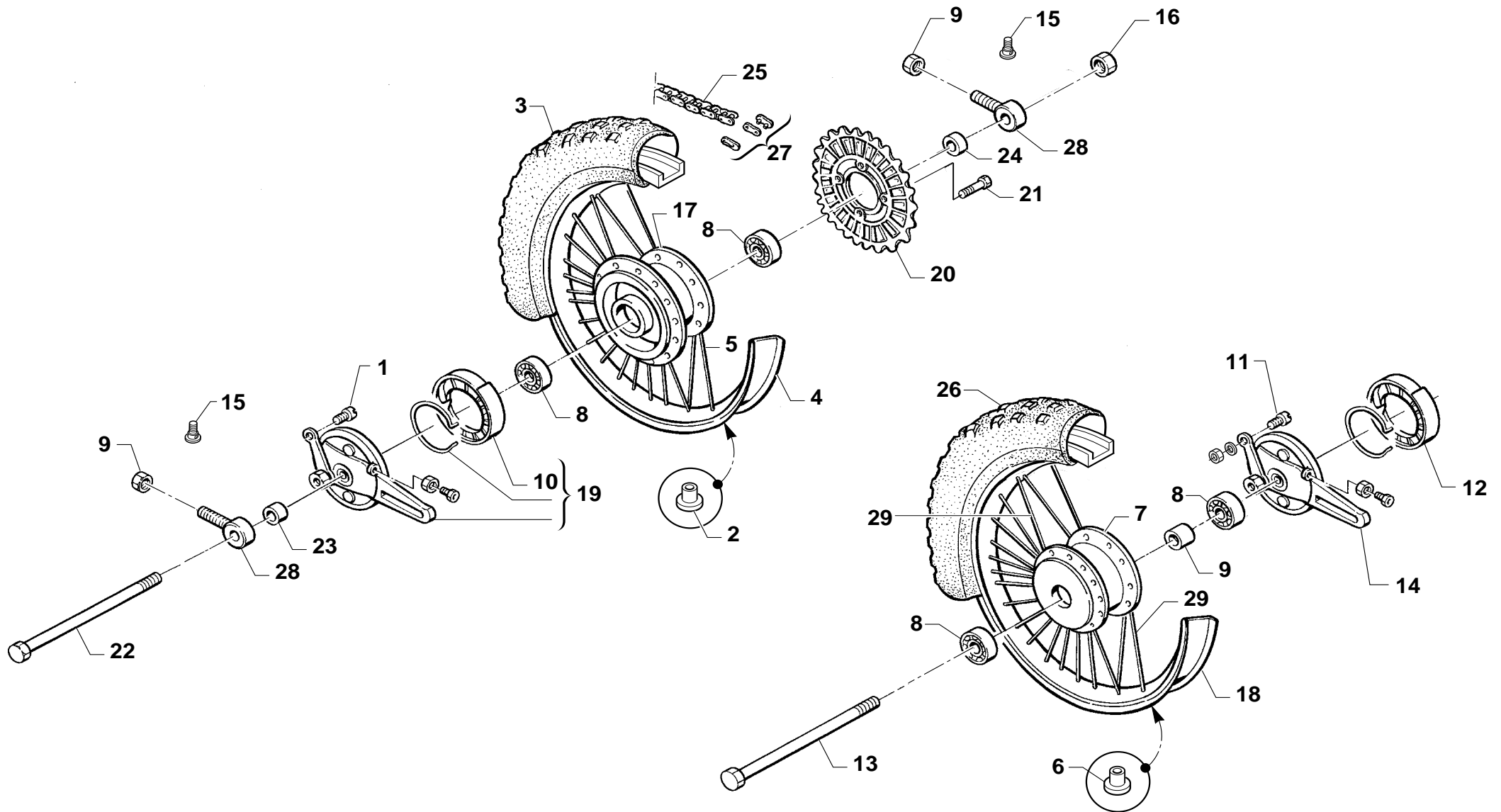

Pos. No. N. Index. Pos.	N.codice Code No. Nr. code Code Nr. N. cod.	Denominazione	Description	Désignation	Beschreibung	Descripción	Note Notes Notes Marke Notas	Q.tà Q.ty Q.te M.ge C.ad
1	EI.MT.03570501	Vite	Screw	Vis	Schraube	Tornillo		1
2	N2007502	Nipplo	Nipple	Nipple	Nippel	Nipple		36
3	N0005503	Pneumatico ant.	Tyre	Pneu	Reifen	Neumático		1
4	N3004602	Cerchio	Rim	Jante	Felge	Llanta		1
5	N2007908	Raggio	Spoke	Bras	Speiche	Radio		36
6	N2007501	Nipplo	Nipple	Nipple	Nippel	Nipple		36
7	XH288500	Mozzo	Hub	Moyeau	Radnabe	Cubo		1
8	N0003502	Cuscinetto	Bearing	Roulement	Lager	Cojinete		4
9	N1002603	Dado	Nut	Ecrou	Mutter	Tuerca		2
10	XH295500	Assieme ceppi	Complete brake blocks	Sabots de frein complets	Komplete Bremsbacke	Mordaza compl.		1
11	N2000502	Vite	Screw	Vis	Schraube	Tornillo		1
12	EB8.721.4143	Ceppi	Complete brake blocks	Sabots de frein complets	Komplete Bremsbacke	Mordaza compl.		1
13	XH239000	Perno	Pin	Pivot	Bolzen	Perno		1
14	XH302500	Coperchio ceppi	Cover	Couvercle	Deckel	Tapa		1
15	N1000347	Vite	Screw	Vis	Schraube	Tornillo		2
16	N1002602	Dado	Nut	Ecrou	Mutter	Tuerca		2
17	XH3189A0	Mozzo	Hub	Moyeau	Radnabe	Cubo		1
18	N3005001	Cerchio	Rim	Jante	Felge	Llanta		1
19	XH295600	Coperchio	Cover	Couvercle	Deckel	Tapa		1
20	XH288707	Corona	Ring gear	Couronne	Kranz	Corona		1
21	EI.CO.03550600	Vite	Screw	Vis	Schraube	Tornillo		5
22	XH239005	Perno	Pin	Pivot	Bolzen	Perno		1
23	XH238920	Distanziale	Spacer	Entretoise	Distanzstück	Separador		1
24	XH238921	Distanziale	Spacer	Entretoise	Distanzstück	Separador		1
25	N0009005	Catena	Chain	Chaîne	Kette	Cadena		1
26	N0005511	Pneumatico	Tyre	Pneu	Reifen	Neumático		1
27	N0009102	Giunto	Coupling	Joint	Kupplung	Junta		1
28	XH302401	Tendicatena	Chain adjuster	Tendeur de chaine	Kettenspanner	Tensor de cadena		2
29	N2008011	Raggio SX	L.H. spoke	Bras G	Speiche L	Radio IZQ		36